



**T-APS**  
**T1/E1 Protection Switch**  
**Item # 1130052**

## General Description

Dataprobe's Model T-APS Automatic Protection Switch allows for protection of T1 or E1 circuits. The Model T-APS can be used for protecting switch full or fractional services, as well as single ended applications. The unit can be configured for use in Framed or unframed network protocol applications. It is designed for use with redundant circuits and automatically switches paths in order to maintain service. The T-APS provides both serial and Ethernet connectivity for remote access and is SNMP compatible. Local and remote alarm notifications are provided for circuit failures.

The T-APS can be used either in end-to-end or customer premise to C.O. configurations.

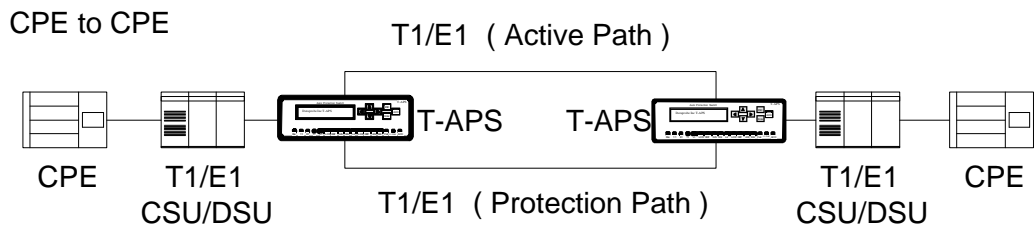
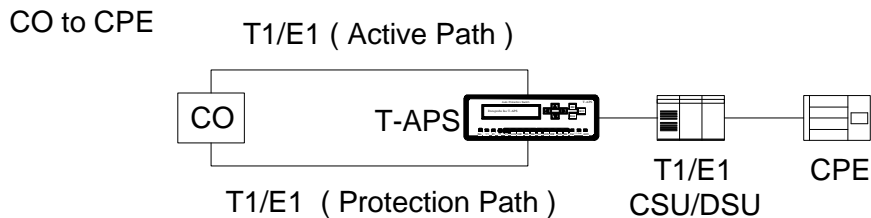

## Features

- T1 or E1 interface selectable
- 1+1 or 1:1 automatic switching.
- Selectable alarm threshold and switching activation thresholds.
- Configurable via front panel, RS-232 serial port or Ethernet Network.
- SNMP Management
- Both active and standby line status monitoring.
- T1/E1 circuit failure alarm output.
- Power-Fail cutout circuit
- Local and remote control of switching functions.
- End to end or end to C.O. auto-switching capability.
- 2 x24 LCD display panel
- Dual Power Inputs -48 VDC and 90 ~ 250 VAC power input (DC Priority)

REF: K3/T-APS\_V050324D.DOC

Technical Support Hotline: (201) 967-8788



**11 Park Place / Paramus, New Jersey 07652**  
**TEL: 201-967-9300 FAX: 201-967-9090**  
Website: [www.dataprobe.com](http://www.dataprobe.com) Email: [tech@dataprobe.com](mailto:tech@dataprobe.com)

**Table of Contents**

<b><i>General Description</i></b>	<b>1</b>
<b><i>Features</i></b>	<b>2</b>
<b><i>Installation</i></b>	<b>3</b>
<b><i>LED Indicators:</i></b>	<b>4</b>
<b><i>Setup</i></b>	<b>5</b>
<b><i>Alarm Contacts</i></b>	<b>11</b>
<b><i>RS-232 Setup Port</i></b>	<b>12</b>
<b><i>SNMP Ethernet Port</i></b>	<b>12</b>
<b><i>Specifications</i></b>	<b>13</b>
<b><i>Technical Support &amp; Warranty</i></b>	<b>14</b>

## Installation

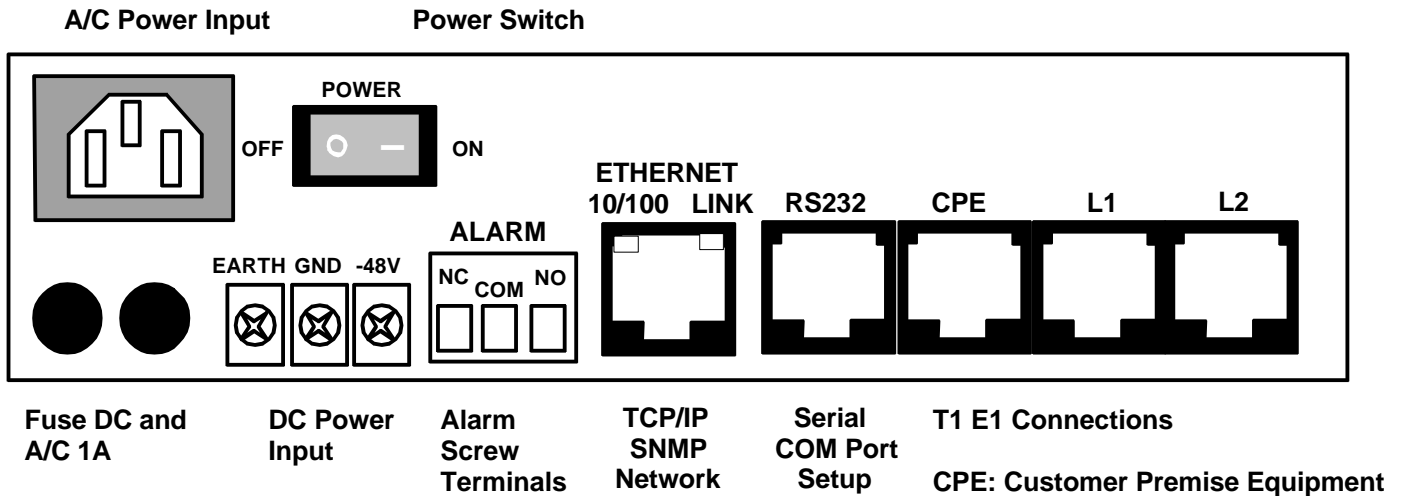

### RJ45 PIN Assignments::

#### CPE, L1, and L2

- CPE: Customer Premise Equipment
- L1: Line 1, Active Path
- L2: Line 2, Protection Path

Pin	Assignment
1	Receive Data
2	Receive Data
3	No Connection
4	Transmit Data
5	Transmit Data
6	No Connection
7	No Connection
8	No Connection

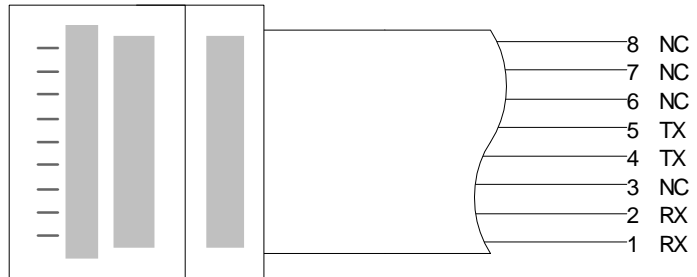

#### RS232 Serial Port

Pin	Assignment
1	No Connection
2	No Connection
3	No Connection
4	Signal Ground
5	Receive Data
6	Transmit Data
7	No Connection
8	No Connection

#### Ethernet Network

Pin	Assignment
1	Transmit +
2	Transmit -
3	Receive +
4	No Connection
5	No Connection
6	Receive -
7	No Connection
8	No Connection

**Environment between two T-APS units:**  
 Media: HDSL, SDH, or FiberMux Setting – Must be set in UNFRAMED Format

## LED Indicators:

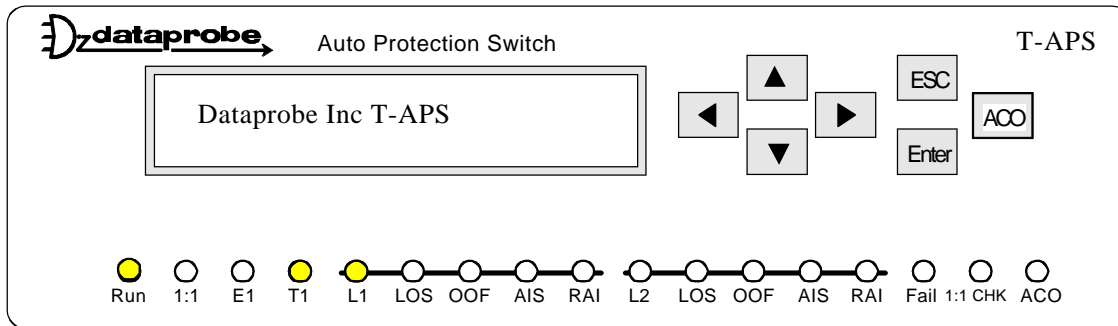

**RUN LED:** While running properly, the RUN display light should be blinking.

**1:1 LED:** The 1:1 light will be on when the units are set in the 1:1 mode. The 1:1 light is off when the units are set in the 1+1 mode. While the LOOK IN function setting is ON, the 1:1 LED will be blinking when the CPE side had a fault.

**E1 LED:** It will be on in the E1 setting.

**T1 LED:** It will be on in the T1 setting.

**L1 LED:** It will be on if L1 is on active path.

**L2 LED:** It will be on if L2 is on active path.

### Blinking events:

First setting the L1 as the active and L2 as protection path, the L1 light will be on and L2 light will be off. In the event of automatic switch to L2, the L2 light will flash quickly before L1 light turns off. The L2 light will then be on and L1 light off if switching succeeds.

In the event of fault from CPE side in L1 active and L2 protection path setting, the LOOK IN Function will apply (see Setup, Selection B LOOK IN ). Setting the LOOK IN Function On will indicate the CPE side fault by showing L1 light on and 1:1 LED light blinking.

In the event of L2 protection path fault, the fault is also indicated as L1 light on and L2 light blinking. The fault from CPE failure or L2 fault can be easily distinguished by MEASURE ERROR RATIO function.

**LOS LED:** Loss Of Signal light will be on if the connection is lost of signals.

**OOF LED:** Out of Frame light will be on if the connection is out of frame.

**AIS LED:** Alarm Indication Signal light will be on when alarm signal received.

**RAI LED:** Remote Alarm Indication light will be on when remote unit fault received

**Fail LED:** Failure Light will be on if a system fault or a circuit failure occurs.

**1:1 CHK** Light on indicates a failure for the units to communicate in the 1:1 mode.

**ACO LED:** The ACO button on the control panel can turn off the Buzzer noise and ACO LED light will be on. Please note: the ACO button does not cancel the ALARM signal. When the ALARM signal is gone, the ACO LED light will be off.

# Setup

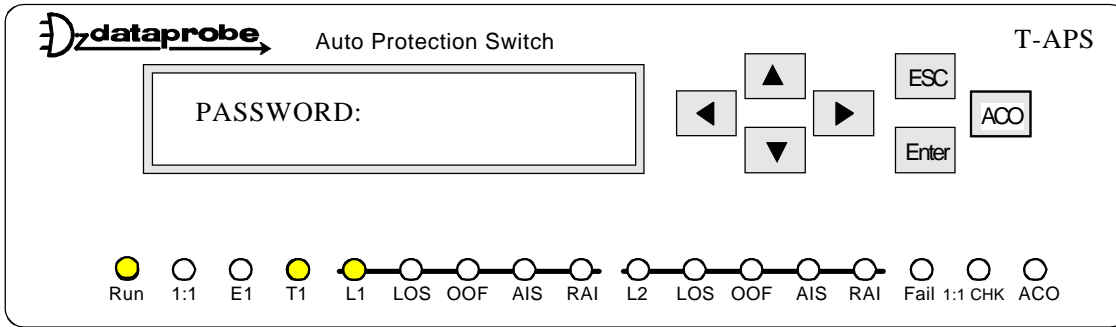

Connect a 110-240 VAC or 48 VDC power source to the unit and turn on the power switch.

## Entering Password and Selecting Setup Functions

The T-APS can be configured using the front panel pushbuttons or accessed thru the RS232 serial port.

**(Factory Password = PASS)**

### Front Panel Selections

Each setting is made using the arrow keys to the right of the display. The display will read "Dataprobe Inc. T-APS" when first powering up the unit or any time the unit has been idle for 2 minutes. Touching a front panel button will restore the display

To enter the password use the *UP* and *Down* arrow buttons to select the required character. After locating the desired character use the *Left* and *Right* arrow buttons to move the cursor the next character position. When the full password is complete press the Enter button.

After entering the correct password, Setup Menu appears.

Scroll up or down to the desired feature and press Enter to select.

The Asterisk (\*) indicates the currently selected option. To change options, use the left or right arrow then press Enter.

To return to the Setup Menu again, press Escape.

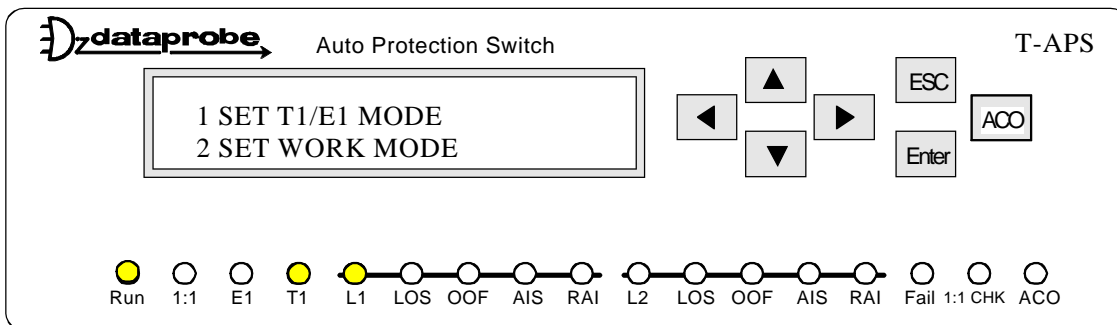

**1: SET T1/E1 MODE**

**BOLD TYPE = Recommended Settings**

After selecting T1, T1 Light will be on.

After selecting E1, E1 Light will be on.

Selections for Line Format and Line Code depend are different if T-1 or E-1 is selected here.

**2: SET WORK MODE**

**1+1** End to End Full T Service application. Data sent on both Active and Protection Path. T-APS duplicates CPE Tx data on both lines and the better quality signal is selected from end to end.

**1:1** Single Ended, or Fractional T Service application. Data sent on Active Path. Protection Path used for circuit performance and communication between T-APS units.

**T1/E1 Auto Protection Switch 1+1 and 1:1  
Comparison Chart**

Item	Function	1+1	1:1
1	Switching Time (within)	25ms	12ms
2	Ability to retrieve protection path status (Good or Bad) from CO or CPE.	Yes	No
3	Manual switching to working path on both ends (CO or CPE)	Yes	No
4	Single Ended Application	No	Yes

Note: Referring T-APS installed in both CO to CPE sides

CO: Central Office

CPE: Customer Premises Equipment

**3: SET LINE FORMAT**

T1 Setting Selections: [ UNFRAMD SF **ESF** ]

E1 Setting Selections: [ UNFRAMD CAS CCS CAS&C **CCS&C** ]

Environment between two T-APS units:

Media:  
HDSL,SDH, or FiberMux Setting – Must be set in UNFRAMED Format

**4: SET LINE CODE**

T1 Setting: Selections - [ **B8ZS** AMI ]

E1 Setting: Selections - [ **HDB3** AMI ]

5: RX SENSITIVITY (NETWORK)Selections – [ LONG **SHORT** ]

LONG: T1 Setting Sensitivity is –36 dB.

E1 Setting Sensitivity is –43 dB.

SHORT: T1 Setting Sensitivity is –15 dB.

E1 Setting Sensitivity is –10 dB

6: SET BUILDOUT (NETWORK)T1Setting Selections: [ **DSX1-1** DSX1-2 DSX1-3 DSX1-4 DSX1-5 -7.5dB -15dB -22dB ]

DSX1-1 0 to 133 feet

DSX1-2 133 to 266 feet

DSX1-3 266 to 399 feet

DSX1-4 399 to 533 feet

DSX1-5 533 to 655 feet

-7.5dB CSU

-15dB CSU

-22dB CSU

E1 Setting Selections: [ **120Nor** 120Hi ]

120 Nor: 1200 Normal Return Loss.

120 Hi: 1200 High Return Loss.

7: RX SENSITIVITY (USER)Selections - [ LONG **SHORT** ]

LONG: T1 Setting Sensitivity is –36 dB.

E1 Setting Sensitivity is –43 dB.

SHORT: T1 Setting Sensitivity is –15 dB.

E1 Setting Sensitivity is –12 dB.

8: SET BUILDOUT (USER)T1Setting Selections: [ **DSX1-1** DSX1-2 DSX1-3 DSX1-4 DSX1-5 -7.5dB -15dB -22dB ]

DSX1-1: 0 to 133 feet

DSX1-2: 133 to 266 feet

DSX1-3: 266 to 399 feet

DSX1-4: 399 to 533 feet

DSX1-5: 533 to 655 feet

-7.5dB CSU

-15dB CSU

-22dB CSU

E1 Setting Selections: [ **120Nor** 120Hi ]

120 Nor: 1200 Normal Return Loss.

120 Hi: 1200 High Return Loss.

## 9: SET AUTOMATIC / MANUAL SWITCHING

Selections - [ **AUTO**    MANUAL ]

**AUTO:** Once the bit error exceeds the preset threshold value or other connection failures, the system will automatically switch from Active path to Protection path.

**MANUAL:** No automatic switching will occur. Use the selection 5 to perform switching

### A: SELECT ACTIVE PATH

Selections - [ **PATH-1**    PATH-2 ]

### B: ENABLE LOOK-IN MODE

Selections [ **ENABLE**    DISABLE ]

T-APS Master and Slave unit will do a checking function to the CPE signal before switching from active path to the protection path.

**Enable:** T-APS will be enabled to check CPE signals. In the event of excessive bit errors from the CPE side to T-APS, T-APS will not perform switching. Enable Look-In may increase a few milli-second to the switching time.

**Disable:** T-APS will be disabled to check CPE signals. In the event of excessive bit errors from the CPE to T-APS, T-APS will perform switching in all events including excessive bit errors from CPE side.

### C: SET LCV ALARM RATIO

Set Line Code Violation Error Ratio

Selections:

$$1E-7 = 1 \times 10^{-7}$$

$$5E-6 = 5 \times 10^{-6}$$

$$1E-5 = 1 \times 10^{-5}$$

$$1E-4 = 1 \times 10^{-4}$$

$$\mathbf{1E-3 = 1 \times 10^{-3}}$$

Once the Line Code Violation Error Ratio exceeds the preset threshold value, it will then switch the ACTIVE PATH to the PROTECTION PATH.

### D: SET LCV CLEAR RATIO

Set Line Code Violation Error Ratio

Selections:

$$1E-9 = 1 \times 10^{-9}$$

$$1E-8 = 1 \times 10^{-8}$$

$$1E-7 = 1 \times 10^{-7}$$

$$1E-6 = 1 \times 10^{-6}$$

$$\mathbf{1E-5 = 1 \times 10^{-5}}$$

Once the Line Code Violation Clear Ratio achieves the preset threshold value, it will then switch back from PROTECTION PATH to the ACTIVE PATH.

E: SET FRAME ALARM RATIO

Selections:

$$1\text{E-}5 = 1 \times 10^{-5}$$

$$1\text{E-}4 = 1 \times 10^{-4}$$

$$1\text{E-}3 = 1 \times 10^{-3}$$

$$1\text{E-}2 = 1 \times 10^{-2}$$

$$\mathbf{1\text{E-}1 = 1 \times 10^{-1}}$$

Once the Line Code Violation Error Ratio exceeds the preset threshold value, it will then switch the ACTIVE PATH to the PROTECTION PATH.

F: SET FRAME CLEAR RATIO

Selections:

$$1\text{E-}7 = 1 \times 10^{-7}$$

$$5\text{E-}6 = 5 \times 10^{-6}$$

$$1\text{E-}5 = 1 \times 10^{-5}$$

$$1\text{E-}4 = 1 \times 10^{-4}$$

$$\mathbf{1\text{E-}3 = 1 \times 10^{-3}}$$

Once the Line Code Violation Clear Ratio achieves the preset threshold value, it will then switch back from PROTECTION PATH to the ACTIVE PATH.

G: SET CRC ALARM RATIO

Set Critical Redundancy Check error ratio

Selections:

$$1\text{E-}5 = 1 \times 10^{-5}$$

$$1\text{E-}4 = 1 \times 10^{-4}$$

$$1\text{E-}3 = 1 \times 10^{-3}$$

$$1\text{E-}2 = 1 \times 10^{-2}$$

$$\mathbf{1\text{E-}1 = 1 \times 10^{-1}}$$

Once the Line Code Violation Error Ratio exceeds the preset threshold value, it will then switch the ACTIVE PATH to the PROTECTION PATH.

H: SET CRC CLEAR RATIO

( 1) Set Critical Redundancy Check error ratio

Selections:

$$1\text{E-}7 = 1 \times 10^{-7}$$

$$5\text{E-}6 = 5 \times 10^{-6}$$

$$1\text{E-}5 = 1 \times 10^{-5}$$

$$1\text{E-}4 = 1 \times 10^{-4}$$

$$\mathbf{1\text{E-}3 = 1 \times 10^{-3}}$$

Once the Line Code Violation Clear Ratio achieves the preset threshold value, it will then switch back from PROTECTION PATH to the ACTIVE PATH.

**I: MEASURE ERROR RATIO**

MEASURE ERROR RATIO will measure and display Line Code Violation(LCV), Critical Redundancy Check(CRC), and Frame(FRME).

**J: SET BUZZER ON/OFF**

Selections [ **ON** OFF ]

Setting BUZZER ON, the LED and the BUZZER will alarm in the event of receiving bit errors (LOSS OF AIS RAI). Pressing the [ACO] bottom on the display will stop the BUZZER.

Setting BUZZER OFF will disable the BUZZER function.

**K: SET RECOVERY TIME**

Selections - [ 00 to 99 MINUTES ]

Setting the time interval to recover from protection path to the active path.

Setting Recovery at 00 Minutes – The Protection Path will immediately (00 Minutes) switch back to Active Path when Active Path is in a good condition.

Setting Recovery at XX (01 to 98) Minutes – The Protection Path will switch back to Active Path after Active Path stays in good condition for X Minutes.

Setting Recovery at 99 Minutes – While setting Recovery at 99 Minutes, the Protection Path will not switch back to Active Path. The Protection Path will only switch back to Active Path when experiencing excessive bit errors or lost of signals.

**L: SET GATEWAY ADDRESS**

Assign T-APS Gateway Address. Default: 192.168.000.254

**M: SET SUBNET MASK**

Assign T-APS Subnet Mask. Default: 255.255.255.000

**N: SET SOURCE IP ADDRESS**

Assign T-APS Source IP Address. Default: 192.168.000.073

**O: SET TRAP IP ADDRESS**

Assign T-APS SNMP TRAP alarm IP Address.

Selections [ #1TRAP #2TRAP ]

#1TRAP Default: 192.168.000.069

#2TRAP Default: 000.000.000.000

**P: SET COMMUNITY STRING**

Assign T-APS SNMP Community String (Password)

Selections [ GET SET TRAP ]

GET Default: Public

SET Default: Private

TRAP Default: Public

Q: SET CURRENT DATE

MM/DD/YY: Month / Day / Year

R: SET CURRENT TIME

HH/MM/SS: Hour / Minute / Second

S: SET PASSWORD

Default Password – **PASS**

T: USE FACTORY DEFAULTS

Selections [ YES NO ]

U: SHOW CURRENT LINE

Displays either Line 1 or Line 2 current selected by T-APS.

V: SHOW MAC ADDRESS

Displays the programmed MAC address of the unit.

W: EXIT

Exit T-APS setup configuration.

T-APS requires a PC using the RS-232 CONSOL PORT to change password.

Selections [ YES NO ]

Selecting YES will logout T-APS setup, and it will require a password to enter.

Selecting LOGOUT NO will exit this function.

**Alarm Contacts**

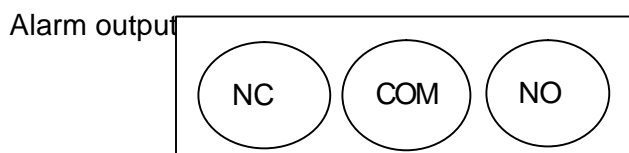

The Alarm relay Contact definition:

NC – Normally Closed conditions:

1. Power supply OFF.
2. Circuited error detected, and T-APS switches from working path to protection path. Failure LED will be also ON. Once all errors have been cleared, T-APS will switch back to working path, and the NC condition will returned to NO. Failure LED will then be OFF.

NO- Normally Open conditions:

1. Power supply ON.
2. T-APS operating normally in working path..

NC will activate from NO to NC functions like a self-diagnostic check up on the equipment itself (T-APS). For example, in the event of system (T-APS) failure, the Alarm contacts of T-APS will change from Normal Open to Normal Close.

## RS-232 Setup Port

The Setup Port can be used to set the parameters of the T-APS. It includes all the functions of the front panel display setup with the addition of Function M: Set Password.

You can access the Setup Port using a VT100 terminal, or PC running terminal emulation software (like Hyperterminal).

The RS-232 port settings are: 9600bps, 8 Data Bits, 1 Stop Bit, No Parity ( **9600 N 8 1**) Once you connect to the T-APS, press the Escape Key (Esc) to display the password prompt. Enter the Password and press Enter. The setup menu is displayed.

**Factory preset password: PASS**

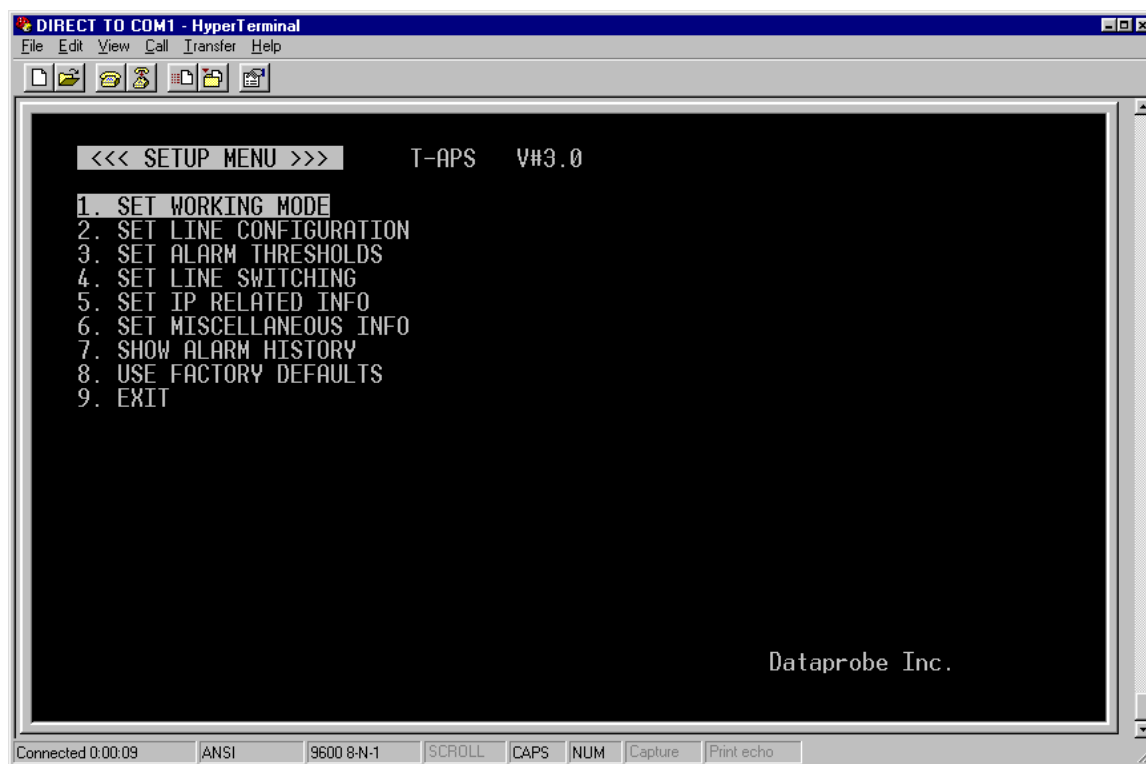

Enter the # of the settings or features you wish to change. When all setup is completed, you may select 9 to Logout. A **Current Settings** screen will be displayed with a confirmation for exiting.

## Current Settings

The following settings screen will be displayed showing the current configuration. This will require the password to be re-entered when next accessing the setup.



```
DIRECT TO COM1 - HyperTerminal
File Edit View Call Transfer Help
[Icons]
<<< SETUP MENU >>>      T-APS  V#3.0
                          CURRENT SETTINGS:
T1/E1 MODE      : T1 MODE      OPERATION MODE   : 1:1 MODE
LINE FORMAT    : ESF FORMAT   LINE CODE       : B8ZS CODE
RECEIVE(NETWORK) : SHORT HAUL  BUILDOUT(NETWORK) : DSX1-1
RECEIVE(USER)  : SHORT HAUL  BUILDOUT(USER)   : DSX1-1
SWITCHING METHOD : AUTOMATIC SWITCHING ACTIVE LINE      : LINE 1
LOOK-IN MODE   : DISABLE
LCV ALARM RATIO : 1E-4        LCV CLEAR RATIO  : 1E-5
FRAME ALARM RATIO : 1E-1       FRAME CLEAR RATIO : 1E-3
CRC ALARM RATIO  : 1E-1       CRC CLEAR RATIO  : 1E-3
BUZZER STATE    : BUZZER ON   RECOVERY TIME    : 00 MINUTE(S)
GATEWAY ADDRESS : 192.168.0.254 SUBNET MASK VALUE : 255.255.255.0
SOURCE IP ADDRESS : 192.168.0.73 MAC ADDRESS      : 00.0A.E3.00.03.AD
#1 TRAP IP ADDRESS: 192.168.0.69 #2 TRAP IP ADDRESS: 0.0.0.0
COMMUNITY STRING(GET) : public  COMMUNITY STRING(SET) : private
COMMUNITY STRING(TRAP): public  PASSWORD         : PASS

                          SURE TO EXIT?  1. YES
                                              2. NO

                          Dataprobe Inc.
```

Connected 0:00:38 | ANSI | 9600 8-N-1 | SCROLL | CAPS | NUM | Capture | Print echo

## SNMP Ethernet Port

The system can be managed by SNMP through standard management software. Dataprobe provides a private MIB which is available on our web site at: <http://www.dataprobe.com/files/switch/taps/taps.mib>

### Setting I/P Address

The T-APS comes with factory installed IP address **192.168.1.254**. In most cases this will need to be changed.

Consult your Network Administrator to determine the appropriate IP address. There are two methods to change the IP address.

- Front Panel Switches
- Serial Port

To set the IP address, the hardware (MAC) address must be known. This address is located on a label on the bottom of the unit or can be accessed thru serial port or the front panel display. The syntax for the MAC address is: nn-nn-nn-nn-nn-nn

IP Address, Subnet Mask and Gateway: Enter the appropriate information in dotted decimal format (xxx.xxx.xxx.xxx). If you are unsure of the entries, consult your network administrator.

#### Example of MIB Walk

sysDescr	.0	DisplayString	Dataprobe T-APS #V3.0	
sysObjectID	.0	ObjectIdentifier	1.3.6.1.4.1.17183.608	
sysUpTime	.0	TimeTicks	0-0:47:30.0	
sysContact	.0	DisplayString	support@dataprobe.com	
sysName	.0	DisplayString	T-APS	
sysLocation	.0	DisplayString	11 Park Place / Paramus	New Jersey 076552
sysServices	.0	INTEGER	72	
mode	.0	Enum	t1 (1)	
workMode	.0	Enum	mode-1plus1 (1)	
frameFormat	.0	Enum	t1-ESF (3)	
lineCode	.0	Enum	code-B8ZS (1)	
equipmentHaul	.0	Enum	(7) is not in the MIB!	
equipmentBuildOut	.0	Enum	t1-DSX1 (1)	
facilityHaul	.0	Enum	shortHaul (2)	
facilityBuildOut	.0	Enum	t1-DSX1 (1)	
switchingMode	.0	Enum	autoMode (1)	
activePath	.0	Enum	path1 (1)	
lookIn	.0	Enum	disable (2)	
lcvErrorCount	.0	Enum	lcvErr1E-3 (1)	
lcvClearCount	.0	Enum	lcvClr1E-5 (1)	
frameErrorCount	.0	Enum	frameErr1E-1 (1)	
frameClearCount	.0	Enum	frameClr1E-3 (1)	
crcErrorCount	.0	Enum	crcErr1E-1 (1)	
crcClearCount	.0	Enum	crcClr1E-3 (1)	
buzzerOnOff	.0	Enum	buzzerON (1)	
recoveryTime	.0	INTEGER	2	
currentPath	.0	INTEGER	1	

## Specifications

### T1 Interface

Bit Rate	1.544 M b/s
Line Code	AMI B8ZS
Frame Format	SF ESF Unframed
Bit Rate	1.544M b/s
Impedance	100 Ohms Resistive Balanced
Input Level	0-36 dB
Output Level	6V p-p
Line Build Out	0-655 feet

### E1 Interface

Bit Rate	2.048 M b/s
Line Code	AMI HDB3
Frame Format	CCS CAS CCS+CRC CAS+CRC Unframed
Impedance	120 Ohms Resistive Balanced
Input Level	0-43 dB
Output Level	6V p-p
Line Build Out	0-655 feet

### LED Status Display

RUN 1:1 T1 or E1 Line 1 and Line2 LOS OOF AIS RAI Fail ACO

### ALARM Contacts

Form C relay 0.5A 30VDC MAX

### Automatic Switching Parameter Programmable

Code Violation	10-3	10-6
CRC Error	10-1	10-3
Frame Error	10-1	10-3
AIS	Unframed or Framed	
Loss of Signal		
Fault Duration	500 ms	1000 ms 1500 ms 2000 ms
Recovery Interval	0 Minute	1~98 Minutes 99 Minutes (Toggle)

Console Port	RS-232 VT-100)
Network	10BaseT Ethernet
Power	90-250V AC 47-63Hz and -48V±5V DC
Weight	1.1 KG
Dimension	200mm W×70 mm H × 240 mm D
Operating Temperature	0°C~ 50°C
Relative Humidity	5% 90%, Non-condensing
Regulatory Compliance	FCC Part 15 Class A
Reliability	MTBF 44,000 hrs

## TECHNICAL SUPPORT, RETURNS & WARRANTY

Dataprobe Technical Support is available 8:30AM to 5:30PM ET to assist you in the installation and operation of this product. To obtain Technical Support call our [Tech Support Hotline at 201-967-8788](tel:201-967-8788), or Email us at [tech@dataprobe.com](mailto:tech@dataprobe.com). Please have the following information available when you call:

- Model of Product
- Serial Number
- Data of Purchase
- Name of Seller (if other than Dataprobe)

If you purchased this product through an **Authorized Dataprobe Reseller**, you should contact them first, as they may have information about the application that can more quickly answer your questions.

### WARRANTY

Seller warrants this product, if used in accordance with all applicable instructions, to be free from original defects in material and workmanship for a period of One Year from the date of initial purchase. If the product should prove defective within that period, Seller will repair or replace the product, at its sole discretion.

Service under this Warranty is obtained by shipping the product (with all charges prepaid) to the address below. Seller will pay return shipping charges. Call Dataprobe Technical Service at (201) 967-8788 to receive a Return Materials Authorization (RMA) Number prior to sending any equipment back for repair. Include all cables, power supplies and proof of purchase with shipment.

**THIS WARRANTY DOES NOT APPLY TO NORMAL WEAR OR TO DAMAGE RESULTING FROM ACCIDENT, MISUSE, ABUSE OR NEGLIGENCE. SELLER MAKES NO EXPRESS WARRANTIES OTHER THAN THE WARRANTY EXPRESSLY SET FORTH HEREIN. EXCEPT TO THE EXTENT PROHIBITED BY LAW, ALL IMPLIED WARRANTIES, INCLUDING ALL WARRANTIES OF MERCHANT ABILITY OR FITNESS FOR ANY PURPOSE ARE LIMITED TO THE WARRANTY PERIOD SET FORTH ABOVE; AND THIS WARRANTY EXPRESSLY EXCLUDES ALL INCIDENTAL AND CONSEQUENTIAL DAMAGES.**

Some states do not allow limitations on how long an implied warranty lasts, and some states do not allow the exclusion or limitation of incidental or consequential damages, so the above limitations or exclusions may not apply to you. This warranty gives you specific legal rights, and you may have other rights which vary from jurisdictions to jurisdiction.

**WARNING:** The individual user should take care to determine prior to use whether this device is suitable, adequate or safe for the use intended. Since individual applications are subject to great variation, the manufacturer makes no representation or warranty as to the suitability of fitness for any specific application.

**Dataprobe Inc.  
11 Park Place  
Paramus, NJ 07652**