

## 1. General Description

The iBoot-IO is a remote controlled power On / Off switch. It is designed to be controlled by any dry contact, such as switch, relay or open collector relay drive circuit.

iBoot-IO handles worldwide power from 105-240VAC. It is capable of switching up to 12 Amps at 120VAC and 10 Amps at 220 VAC.

Screw terminals provide connection to the contact closure control and feedback circuit. Power connections are made using supplied IEC-320 to NEMA 1-15 cables.

## 2. Connections

**Connect Powered Device** Connect the device to be powered ON and OFF to the IEC receptacle marked Switched Outlet. An IEC 320 to North American (NEMA 5-15) power cord is included for connecting the iBoot-G2 outlet to the device to be controlled.



**Make sure that the combined load of all controlled devices does not exceed 12 Amps for 105-125VAC or 10 Amps for 210-240VAC.**

**Connect Power Mains** Connect the supplied power cord to the connector labeled AC Input, and the other end to your AC source. If a power cord with a different terminating plug is required, be sure it is properly rated and meets all the required local electrical standards.

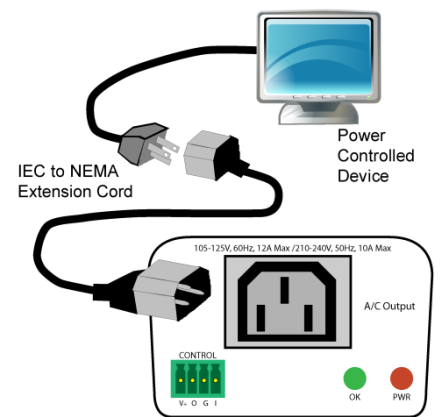

*Connect Powered Device using Supplied Cord*

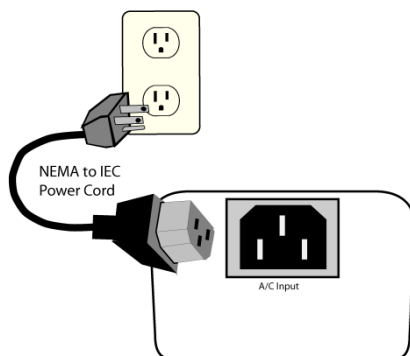

*Connect to Power Mains using Supplied Cord*

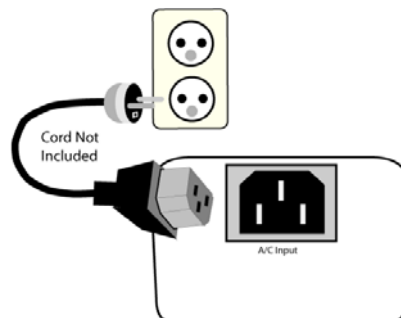

*Other Power Cords Sourced Locally*

**Inputs and Outputs** The screw terminal blocks are on removable connectors for easy cable fabrication. See Specification below for additional connection information.

iBoot-IO	Function
I Control Input	Open = Power ON, Ground= Power OFF
G Ground	Common Ground
O Feedback Output	High(Open) = Power OFF, Low (Ground) = Power ON

Connections to the iBoot-Exp are made using screw terminal blocks. The screw terminal blocks are on removable connectors for easy cable fabrication.

Make sure screw terminals are tightened securely and that there are no loose strands of cable, or excessive stripped wires.

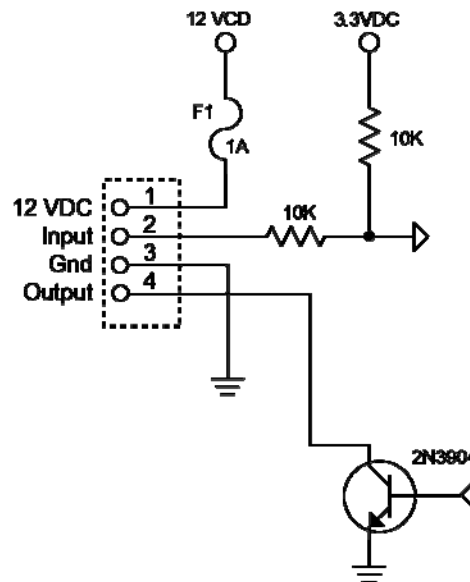

*Electrical Connections for Control and Feedback*



*Proper Screw Terminal Connections*

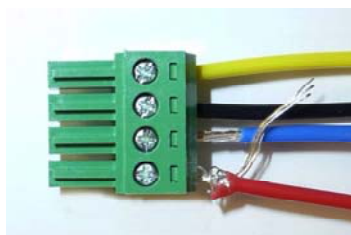

*Poor Screw Terminal Connections.  
Note Loose Wires and Excessive Stripping*

### 3. LED Indicators

LED	OFF	ON
OK - Green	Power Main Disconnected	Power Main Connected
PWR - Red	Power Outlet Off	Power Outlet On

## 4. Mounting Options

iBoot-G2+ is suitable for desktop or shelf mounting. A mounting kit for wall and DIN rail mounting is available. Order part:

1920034 Mounting Kit for iBoot-G2+ G2 Series



**Remove all cables from the unit prior to installing or removing any mounting hardware.**

1920033 Mounting Kit  
iBoot G2 Series



### Installing the Wall Mounting Kit

1. Remove the four mounting screws from the underside of the unit.

Do not disassemble the unit.



2. Install the wall mounting ears to the unit using the screws removed in Step 2



3. The unit is ready for wall mounting.



4. Use M3 or #4 screws (not included) for attachment to suitable surface

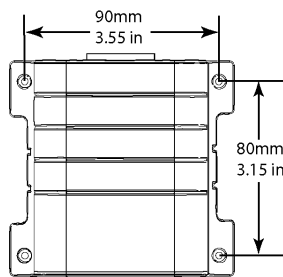

### DIN Rail Mounting

1. Install the Wall Mounting Kit as shown.



2. Install the DIN rail clips using the four screws provided.



3. Ready for DIN rail mounting.



## 5. Specifications

### 5.1. Physical

Height	2.0" 60mm
Width	3.2" 82mm
Depth	4.2" 107mm
Weight	8.6 oz 244g
MTBF	400,000 Hours
Temperature	0 – 50 degrees C

### 5.2. AC

Input	IEC 320 C14
Input Cord	16AWGX3C 10A 250 UL/CSA/VDE Rated (1.25mm2X3C)
Voltage Range	Auto Sensing 105-240 VAC
Switched Receptacle	IEC 320 C13
Capacity	12 A Max at 105-125 VAC, 10 A Max at 210-240 VAC

### 5.3. Power and Control Connections

Four position removable screw terminals. 18AWG maximum. Maximum distance to iBoot-G2+ 330feet/100m using 24AWG wire.	
I	Control Input. Contact closure or open collector transistor circuit only
O	Status feedback. Open collector circuit. Open = Power On, Grounded = Power Off

### 5.4. Compliance

UL/cUL	UL60950 Listed I.T.E File No. 188
CE	Directives 89/336/EEC, 92/31/EEC and 93/68/EEC EN 60950: 3rd Edition EN 55022: 1998 Class B
FCC	Part 15 Class B

## 6. Important Safety Instructions

When using this product, basic safety precautions should always be followed to reduce the risk of fire, electric shock, and injury to persons, including the following:

1. Read and understand all instructions.
2. Follow all warnings and marked on the product.
3. Unplug this product from the wall outlet before cleaning. Do not use liquid cleaners or aerosol cleaners. Use a damp cloth for cleaning.
4. Do not use this product in an outdoor environment or near water, for example, near a bath tub, wash bowl, kitchen sink, or laundry tub, in a wet basement, or near a swimming pool.
5. Do not place this product on an unstable cart, stand, or table. The product may fall, causing serious damage to the product.
6. Slots and openings in this product and the back or bottom are provided for ventilation to protect it from overheating; these openings must not be blocked or covered. The openings should never be blocked by placing the product on the bed, sofa, rug, or other similar surface. This product should never be placed near or over a radiator or heat register. This product should not be placed in a built-in installation unless proper ventilation is provided.
7. This product should be operated only from the type of power source indicated on the marking label. If you are not sure of the type of power supply to your home, consult your dealer or local power company.
8. This product is equipped with a three wire grounding type plug, a plug having a third (grounding) pin. This plug will only fit into a grounding type power outlet. This is a safety feature. If you are unable to insert the plug into the outlet, contact your electrician to replace your obsolete outlet. Do not defeat the safety purpose of the grounding type plug. Do not use a 3-to-2 prong adapter at the receptacle; use of this type adapter may result in risk of electrical shock and/or damage to this product.
9. Do not allow anything to rest on the power cord. Do not locate this product where the cord will be abused by persons walking on it.
10. Do not overload wall outlets and extension cords as this can result in the risk of fire or electric shock.
11. Never push objects of any kind into this product through slots as they may touch dangerous voltage points or short out parts that could result in a risk of fire or electrical shock. Never spill liquid of any kind on the product.
12. To reduce the risk of electrical shock, do not disassemble this product, but take it to a qualified serviceman when some service or repair work is required. Opening or removing covers may expose you to dangerous voltages or other risks. Incorrect re-assembly can cause electric shock when the appliance is subsequently used.
13. Unplug this product from the wall outlet and refer servicing to qualified service personnel under the following conditions:
  - a) When the power supply cord or plug is damaged or frayed.
  - b) If liquid has been spilled into the product.
  - c) If the product has been exposed to rain or water.
  - d) If the product does not operate normally by following the operating instructions. Adjust only those controls that are covered by the operating instructions because improper adjustment of other controls may result in damage and will often require extensive work by a qualified technician to restore the product to normal operation.
  - e) If the product has been dropped or has been damaged.
  - f) If the product exhibits a distinct change in performance.
14. Avoid using a telephone (other than a cordless type) during an electrical storm. There may be a remote risk of electric shock from lightning.
15. Do not use the telephone to report a gas leak in the vicinity of the leak.
16. Do not exceed the maximum output rating of the auxiliary power receptacle.

Save These Instructions

## 7. Technical Support and Warranty

Dataprobe Technical Support is available 8:30AM to 5:30PM ET to assist you in the installation and operation of this product. To obtain Technical Support call 201- 934-5111, or Email us at [tech@dataprobe.com](mailto:tech@dataprobe.com). Please have the following information available when you call:

- Model of Product
- Lot and Version Numbers
- Data of Purchase
- Name of Seller (if other than Dataprobe)

**If you purchased this product through an Authorized Dataprobe Reseller, you should contact them first, as they may have information about the application that can more quickly answer your questions.**

### 7.1. WARRANTY

Seller warrants this product, if used in accordance with all applicable instructions, to be free from original defects in material and workmanship for a period of One Year from the date of initial purchase. If the product should prove defective within that period, Seller will repair or replace the product, at its sole discretion.

Service under this Warranty is obtained by shipping the product (with all charges prepaid) to an authorized service center. Seller will pay return shipping charges. Call Dataprobe Technical Service at (201) 934-5111 to receive a Return Materials Authorization (RMA) Number prior to sending any equipment back for repair. Include all cables, power supplies and proof of purchase with shipment.

THIS WARRANTY DOES NOT APPLY TO NORMAL WEAR OR TO DAMAGE RESULTING FROM ACCIDENT, MISUSE, ABUSE OR NEGLIGENCE. SELLER MAKES NO EXPRESS WARRANTIES OTHER THAN THE WARRANTY EXPRESSLY SET FORTH HEREIN. EXCEPT TO THE EXTENT PROHIBITED BY LAW, ALL IMPLIED WARRANTIES, INCLUDING ALL WARRANTIES OF MERCHANTABILITY OR FITNESS FOR ANY PURPOSE ARE LIMITED TO THE WARRANTY PERIOD SET FORTH ABOVE; AND THIS WARRANTY EXPRESSLY EXCLUDES ALL INCIDENTAL AND CONSEQUENTIAL DAMAGES.

Some states do not allow limitations on how long an implied warranty lasts, and some states do not allow the exclusion or limitation of incidental or consequential damages, so the above limitations or exclusions may not apply to you. This warranty gives you specific legal rights, and you may have other rights which vary from jurisdictions to jurisdiction.

**WARNING:** The individual user should take care to determine prior to use whether this device is suitable, adequate or safe for the use intended. Since individual applications are subject to great variation, the manufacturer makes no representation or warranty as to the suitability of fitness for any specific application.

Dataprobe Inc.

Dataprobe Inc  
1 Pearl Court, Suite B  
Allendale New Jersey 07401

Technical Support  
[tech@dataprobe.com](mailto:tech@dataprobe.com) 201-934-5111  
[www.dataprobe.com/support](http://www.dataprobe.com/support) 201-934-9944