

General Description:

The iBootBar **Model iBB-DC8** is a network controlled, eight port DC power control switch. It supports input voltages of 5 to 30 VDC, and switches the input voltage on eight independent relay switches. Remote control of each relay switch is via web browser, RS-232 serial, Telnet, SNMP. The Internal Modem Version (model iBB-8DC-M) also supports dial up control with either terminal or DTMF dialing tones. Up to 16 iBB-DC8 units can be daisy chained and controlled via one network or serial connection.



Ref: ibbdc8_1.5_v090824e

Table of Contents

<i>Important Safety Instructions</i>	3	<i>Advanced Operation</i>	22
<i>Quick Start</i>	4	DTMF Control	
<i>General Overview</i>	5	Timed Events	
<i>Installation</i>	6	Auto Ping	
Ethernet		SSL Security	
Serial Port		Certificate Upload Utility	
Dial Line		Email Notification	
Expansion		SNMP	
Power Source		Firmware Upgrades	
		Password Recovery	
		Setup and Control Utility	
<i>Configuration</i>	7	<i>Specifications</i>	29
Setup and Control Utility		<i>Compliance Statements</i>	31
Command Line Interface		<i>Modem Certifications</i>	32
Setting the IP Address		<i>SNMP MIB</i>	33
<i>Basic Operation</i>	10	<i>Technical Support, Warranty</i>	34
Web Interface			
Command Line Interface			
Outlet Commands			
User Commands			
Device Commands			
Group Commands			
Web Server Commands			
Telnet Commands			
AutoPing Commands			
Event Commands			
Firmware Upload Commands			
Email Commands			
Time Commands			

Important Safety Information

When using this product, basic safety precautions should always be followed to reduce the risk of fire, electric shock, and injury to persons, including the following:

Disconnect all power cords before servicing!

1. Read and understand all instructions.
2. Follow all warnings in the manual and marked on the product.
3. Unplug this product from the wall outlet before cleaning. Do not use liquid cleaners or aerosol cleaners. Use a damp cloth for cleaning.
4. Do not use this product in an outdoor environment or near water, for example, near a bath tub, wash bowl, kitchen sink, or laundry tub, in a wet basement, or near a swimming pool.
5. Do not place this product on an unstable cart, stand, or table. The product may fall, causing serious damage to the product.
6. Slots and openings in this product and the back or bottom are provided for ventilation to protect it from overheating, these openings must not be blocked or covered. The openings should never be blocked by placing the product on the bed, sofa, rug, or other similar surface. This product should never be placed near or over a radiator or heat register. This product should not be placed in a built-in installation unless proper ventilation is provided.
7. This product should be operated only from the type of power source indicated on the marking label. If you are not sure of the type of power supply to your home, consult your dealer or local power company.
8. This product is equipped with a three wire grounding type plug, a plug having a third (grounding) pin. This plug will only fit into a grounding type power outlet. This is a safety feature. If you are unable to insert the plug into the outlet, contact your electrician to replace your obsolete outlet. Do not defeat the safety purpose of the grounding type plug. Do not use a 3-to-2 prong adapter at the receptacle; use of this type adapter may result in risk of electrical shock and/or damage to this product.
9. Do not allow anything to rest on the power cord. Do not locate this product where the cord will be abused by persons walking on it.
10. Do not overload wall outlets and extension cords as this can result in the risk of fire or electric shock.
11. Never push objects of any kind into this product through slots as they may touch dangerous voltage points or short out parts that could result in a risk of fire or electrical shock. Never spill liquid of any kind on the product.
12. To reduce the risk of electrical shock, do not disassemble this product, but take it to a qualified serviceman when some service or repair work is required. Opening or removing covers may expose you to dangerous voltages or other risks. Incorrect re-assembly can cause electric shock when the appliance is subsequently used.
13. Unplug this product from the wall outlet and refer servicing to qualified service personnel under the following conditions:
 - a) When the power supply cord or plug is damaged or frayed.
 - b) If liquid has been spilled into the product.
 - c) If the product has been exposed to rain or water.
 - d) If the product does not operate normally by following the operating instructions. Adjust only those controls, that are covered by the operating instructions because improper adjustment of other controls may result in damage and will often require extensive work by a qualified technician to restore the product to normal operation.
 - e) If the product has been dropped or has been damaged.
 - f) If the product exhibits a distinct change in performance.
14. Avoid using a telephone (other than a cordless type) during an electrical storm. There may be a remote risk of electric shock from lightning.
15. Do not use the telephone to report a gas leak in the vicinity of the leak.
16. Do not exceed the maximum output rating of the auxiliary power receptacle.

Quick Start

Quick Start Defaults

IP address 192.168.0.254
User Credentials

Username: admin
Password: admin

Command Line Quick Start:

To view outlet status iBootBar> get outlets
To turn on off outlet 1 iBootBar> set outlet 1 off
To reboot outlet 2 iBootBar> set outlet 2 cycle

General Overview

8 Independently controllable outlets	The iBootBar (iBB) series is designed to provide power distribution and remote power control. Each iBB allows eight outlets to be independently switched on and off for reboot, energy management and security. The iBB has many features to make the management of power distribution simple and cost effective:
Web Browser Control	Simple web browser interface is easy to use and provides complete status information and control of the outlets, and groups.
Telnet/Serial CLI control	Telnet and serial access use the same Command Line Interface (CLI) structure and syntax to completely configure the iBootBar, or multiple iBootBars in a cluster configuration.
Multiple users with assigned rights and simultaneous control	Up to 16 users can be assigned administrator or user only rights, plus access to specific outlets and groups. Users only see the outlets and groups they are assigned to.
Multiple iBootBar Cluster Configuration	Up to 16 iBootBars can be linked together and controlled from a single web or CLI interface. One master iBootBar provides the communication to the users and continuously receives status information from the rest of the iBootBars in the cluster. Up to 128 outlets can be controlled in this manner from one IP address.
Grouping of outlets for simultaneous management	Multiple outlets, across multiple iBootBars in clustered configurations can be linked together in named groups and managed together. This allows for example, power cycling all devices of a certain type together.
AutoPing for automatic reboot of crashed systems	Up to 16 systems can be continuously monitored with AutoPing, with automatic power control upon loss of contact. Reboot crashed systems, or provide auto power-up or –down for environmental controls, and notification systems.
Real-Time event control	Set automatic power actions based on your schedule. Restart systems every day to reduce memory bloat. Power up resources only when needed for energy management, lifecycle extension or security.
Internal Modem Option, Data or DTMF Control (Model iBB-DC8-M)	Models with Suffix –M have internal modems with approvals in 36 countries. The modem supports data calls from terminal devices using the CLI, and direct dial from a tone telephone for simple on/off control when more sophisticated means are not available.
SNMP manageable	Setup and Control functions can be linked to any SNMP v1 compatible manager. The iBootBar MIB is downloadable from the website.
Syslog reporting	All activity can be reported to a syslog compatible server.
SSL Security	Web server is secured with Secure Sockets Layer (SSL) encryption.
Certificate Utility	Create, Manage and Upload SSL Certificates

Installation

Ethernet

The iBootBar has a 10/100 Ethernet port. The default address is 192.168.0.254

Serial Port

The iBootBar has a 9 pin D subminiature connector for RS-232 serial control. The connector is configured as DCE for direct connection to a laptop or other terminal device. Default serial parameters are 115,200 bps, 8 data, no parity, 1 stop bit (115200,8,n,1).

Serial Port pinout:

Pin No	Description
1	Data Carrier Detect
2	Receive Data
3	Transmit Data
4	Data Terminal Ready
5	Signal Ground
6	Data Set Ready
7	Request to Send
8	Clear to Send
9	Ring Indicator

Dial Line

Models with suffix -M have an internal modem. This modem supports both data and DTMF control. The modem is approved for use in 36 countries. See Appendix for complete modem certifications. In models without the modem, this jack is not used.

Expansion

The dual Expansion ports allow multiple iBootBars to be linked together and managed from a single point. The expansion connector is 6 wire modular jack. iBootBars can be connected together in a daisy-chain or ring configuration. Up to 16 iBootBars can be clustered together and managed from a single web page or console session. Use 6 conductor data cable to connect iBootBars for cluster configurations. Configuration settings determine whether the iBootBar is the Master or Expansion.

Power Source and Outlets

iBootBar DC-8 is powered from a single 5 – 30 VDC source. Connect the DC Source to the + and – terminals labeled Input. Connect each load to the outlets 1-8 as marked. Each outlet switches the +VDC lead only.

Power Switching:
5 Amps Maximum any Outlet
8 Amps Maximum Total of all Outlets

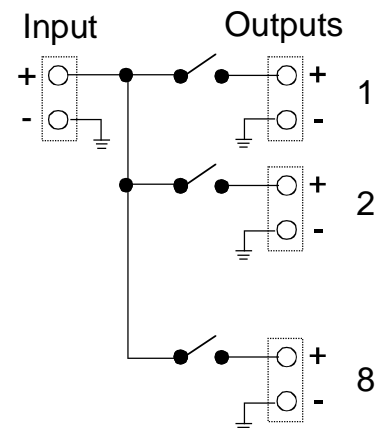

Configuration

Setup & Control Utility

The iBootBar Setup and Control Utility (SCU) utility provides the easiest means to find and configure your iBootBar for use. The SCU can:

1. Automatically discover multiple iBootBars on a local network
2. Add additional iBootBars, not on the local network
3. Download existing configurations from installed iBootBars
4. Save existing configurations for later use or as backup
5. Open saved configurations for change management
6. Clone saved configurations for replication of similar configurations in multiple iBootBars
7. Upload modified configurations to iBootBars
8. Control Power Outlets on one or more iBootBars throughout the network

The iBootBar Setup and Control utility is available on the iBootBar CD or download it from <http://dataprobe.com/ibootbartools.html>

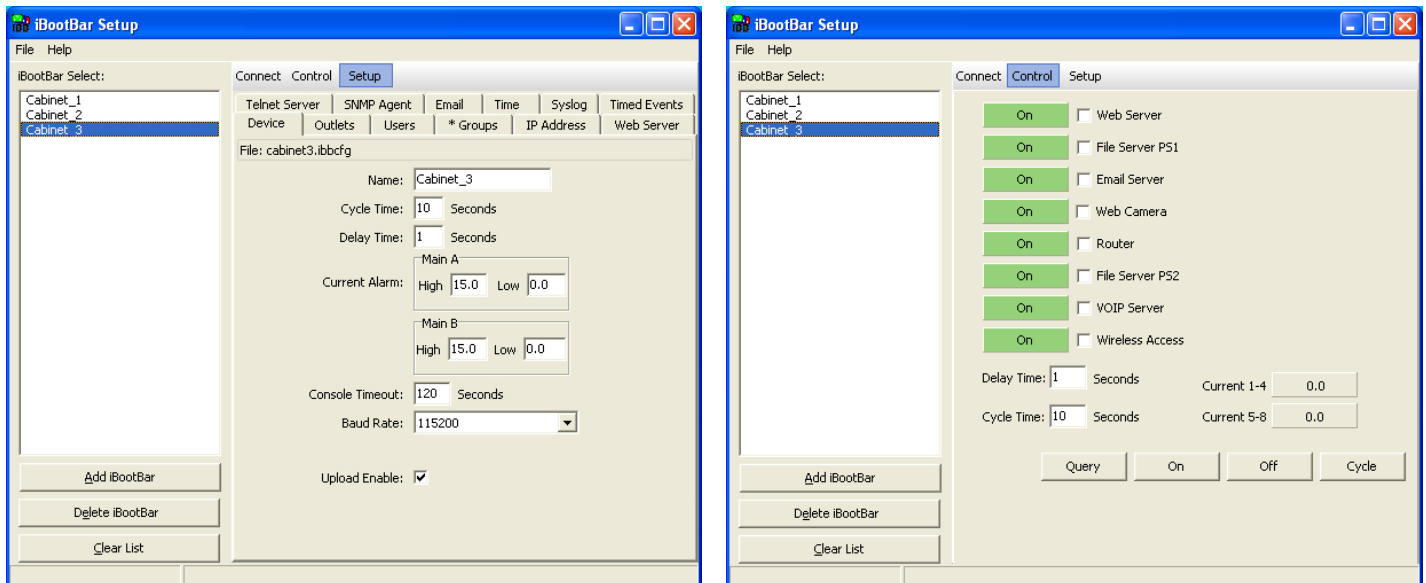

iBootBar Setup and Control Utility

Note: iBB-DC8 units do not provide current monitoring. Reported current draw will report 0.0 amps in all cases.

The Setup and Control Utility only operates with iBootBars attached to the network. iBootBars in a cluster configuration can be configured using the setup and control utility, if they are attached to the network.

Command Line Interface

All configuration parameters are set using the Command Line Interface (CLI). The CLI is accessed through the network, using a telnet client, or through the serial port, or data modem using a terminal client. In iBootBar clusters, all remote iBootBars can be configured and managed through the connection to the Master iBootBar. It is also possible to access, configure and control any Expansion iBootBars directly.

Open a telnet client and point it to the current IP Address of the iBootBar. (Factory Default is **192.168.0.254**) or:

Connect to the Serial port or via PSTN connection to the modem (-M versions) (Factory Default is **115200,8,n,1**)

Upon connection, press Enter, and then enter the username and password when prompted (Factory Default for username and password is **admin**)

A complete list of commands and syntax is found on page 16.

Setting the IP Address

iBootBars comes with factory default IP address 192.168.0.254.

There are three techniques to setting the IP address of the iBootBar.

1. Terminal Client software via Telnet, Serial, Modem.
2. Automatically from a DHCP Server
3. ARP / Ping (factory default)

To configure the mode to set the IP address, access the iBootBar's command line interface (CLI) and use the set ipmode command as indicated below.

Setting the IP address using CLI

These are the basic commands to set the network parameters. After setting these parameters, the iBootBar will need to be rebooted for the settings to take effect. Any command that requires rebooting of the iBootBar will provide a prompt to do so. All commands may be entered as required before rebooting.

Example: Telnet to default IP address 192.168.0.254

```
iBootBar Rev 1.3a.228

User Name: admin
Password: *****

iBootBar > set ipaddress 192.168.1.3
Reboot Required!
OK
iBootBar > set subnet 255.255.255.0
Reboot Required!
OK
iBootBar > set gateway 192.168.1.7
Reboot Required!
OK
iBootBar > reboot

IP Address = 192.168.1.3
```

Once the IP address is set, the following command can be used to prevent DHCP or ARP-Ping from altering it:

```
Set ipmode static
```

Setting the IP address from a DHCP Server

A DHCP server will automatically assign an IP address (dynamic address) as well as Subnet Mask and Gateway to the iBootBar.

To enable this feature, configure the iBootBar with the command `set ipmode dhcp`
Then reboot the iBootBar, or enter the command `reboot`

To find the IP address of the iBootBar you will need to query your DHCP server and locate the MAC address of the iBootBar in the DHCP server's IP / MAC table. You can also access the CLI and use the `get network` command, or use the Discover provision of the iBootBar Setup and Control Utility.

Setting the IP address using ARP / Ping

The ARP / Ping technique uses a PC running a command line (DOS Window) to set the IP Address. To set the IP address using ARP, connect the iBootBar to your local network and apply power. The IP address to be assigned to iBootBar must be use the same subnet as the computer assigning the address. ARP does not work across routed or switched networks.

To set the IP address using ARP, the hardware (MAC) address must be known. This address is located on the bottom of the unit. The syntax for the MAC address is: nn-nn-nn-nn-nn-nn

Windows (98 and Later)

1. Access the iBootBar CLI and enter the `set ipmode arp-ping` command
2. On a PC, open a DOS window. (Run: Command)
3. Type the following command:
`arp -s <IP Address> <MAC Address>`
Where <IP Address> is the desired IP address (in dotted decimal) for the iBootBar and the <MAC address> is the MAC Address of the iBootBar. The MAC Address of the iBootBar is located on the rear of the unit.

Example: `arp -s 63.211.86.165 00-50-c2-05-01-c1 <enter>`
 |new IP addr| |---MAC addr----|

4. Ping the iBootBar to program the IP address into the iBootBar.
Type: `ping <IP Address>`
Note: If the ping command returns "host not responding" 4 times then the address has not been programmed properly. Check the IP or MAC Address for typographical errors. Repeat step 2. If the problem persists, contact the Dataprobe Tech Support.
5. Delete the entry from the ARP cache by typing:
`arp -d <IP Address>`
6. Ping the iBootBar to confirm that it has been programmed.
If the iBootBar fails to respond, repeat steps 2-4 above. If the problem persists, contact Dataprobe Tech Support.

Unix, Linux, MAC and others

Consult your systems administrator for information on how to set an IP Address. The unit should be pinged after the IP Address has been set to confirm proper operation.

Other Configuration Settings

All parameters are set using the CLI. See Page 16 for a complete list.

Basic Operation

Web Interface

The iBootBar web interface provides the easiest means of operating the outlets and monitoring the current status of the units. One or more outlets can be simultaneously controlled with a few mouse clicks. In cluster configurations, all 128 outlets can be managed from the web pages.

The interface is divided into three sections Header, Control, and Status.

Each user will only be able to view and control the outlets, devices and groups that have been assigned to the user.

Note: Current sensing is available only on the A/C versions of iBootBar. Ignore current reporting for DC Versions.

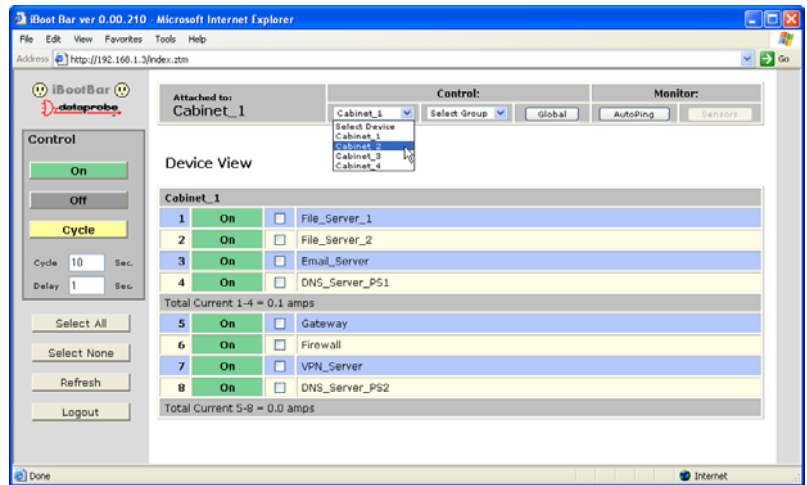

Header The Header identifies the iBootBar currently being accessed. If multiple iBootBars are deployed in a cluster configuration, this will be the master iBootBar.

The Header allows the selection of various status views. To select an individual iBootBar, or predefined group of outlets, click on the one of the two dropdown lists. To select the global view, click on Global. To see the status of the AutoPing feature, click on AutoPing.

Control The Control panel provides the clickable buttons to change status of one or more outlets. Once one or more outlets have been selected, click on the On, Off, or Cycle button. Cycle will perform a timed change in outlet state; either Reboot (On-Off-On), or Cycle (Off-On-Off) depending on the current state of the outlet.

The Cycle timer box allows selection of the length, in seconds, of all cycle or reboot operations. Entries of 1 to 99 seconds are valid.

The Delay timer box allows selection of the delay time, in seconds, between the turning on of each outlet whenever more than one outlets are turned on from the same command. This can be used to prevent over-current draw on initial power up of devices. Entries of 0 to 99 seconds are valid.

The Select All and Select None buttons allow selection or de-selection of all outlets.

Refresh provides an update of the status page to display current conditions. Web pages are static moments in time, so use the Refresh obtain the latest status.

Logout terminates the session.

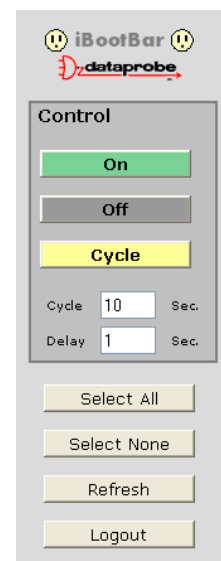

Status The Status window displays the current view, controllable outlets, or other current information. Buttons in the Header select the current view.

Device View

The Device View displays the status of a single device. It shows the current status of each outlet of the device, and allows selection of one or more outlets for control. It also displays the current draw of each inlet and any alarms.

Use the checkboxes to select or de-select any outlet for control.

Outlet Status Outlet status is displayed by a colored text box. The color indicates the current status of the outlet and the text indicates the function being performed.

On	Outlet is On
Cycle	Outlet is On during Cycle. It will turn off when cycle time is complete
Off	Outlet is Off
Reboot	Outlet is Off during Cycle. It will turn on when cycle time is complete
On / Pend	Outlet is Off . It has been commanded to turn on and will do so in its turn based on the delay time.

Inlet Status The current of each power inlet (main) is displayed below the outlets fed by that inlet. High current alarms are highlighted in red, low current alarms are highlighted in yellow.

Group View

The Group View displays the status of a single group. Groups are two or more outlets linked together for simultaneous control. In the group view, each device containing a member of the group is displayed on a line, with the status of the outlets that are group members. Control the group by clicking on the appropriate button in the Control section.

Global View

The Global View displays all iBootBars in one view. Each outlet has a checkbox, allowing multiple outlets to be simultaneously controlled without the need to establish a group. Only outlets that the user has rights to will have status and control checkbox displayed.

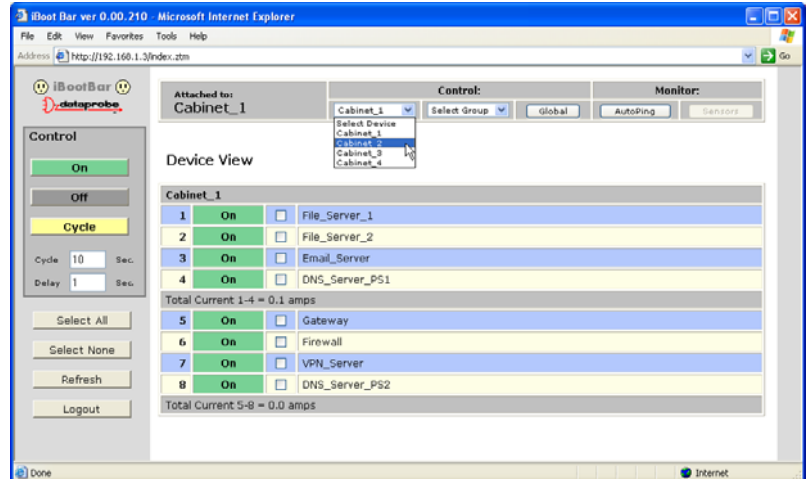

Device View

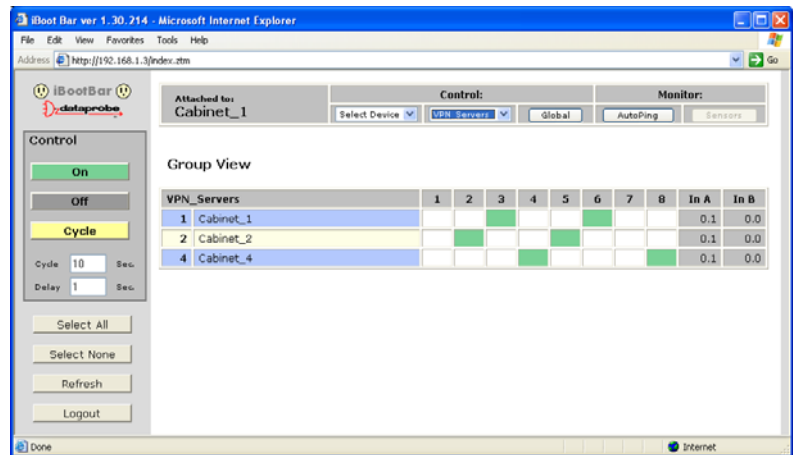

Group View

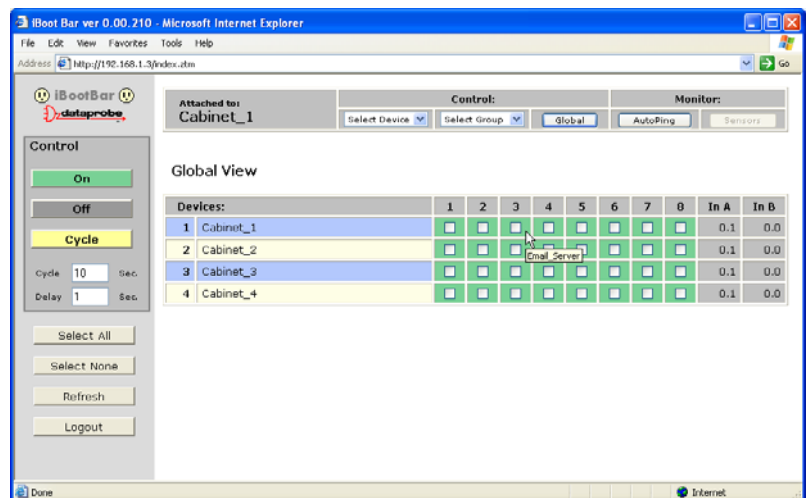

Global View

AutoPing View:

The AutoPing View displays the 16 AutoPing channels, their programmed action and current status.

The status column will display the current status of the AutoPing. The numeric column will display the number of times the AutoPing has been triggered.

A numeric counter other than 0, with the status reporting OK, indicates that there have been previous AutoPing triggers, but the current status is OK.

To reset the trigger count, click on the Reset button.

The screenshot shows the iBootBar web interface in a Microsoft Internet Explorer browser window. The browser title is "iBoot Bar ver 0.00.210 - Microsoft Internet Explorer". The address bar shows "http://192.168.1.3/index.htm". The interface is divided into several sections:

- Control:** Includes buttons for "On", "Off", and "Cycle". Below these are input fields for "Cycle" (set to 10) and "Delay" (set to 1), both in seconds. There are also buttons for "Select All", "Select None", "Refresh", and "Logout".
- Attached to:** "Cabinet_1".
- Control:** Includes "Select Device" and "Select Group" dropdown menus, and a "global" button.
- Monitor:** Includes "AutoPing" and "Sensors" buttons.
- Autoping View:** A table with 16 rows, each representing an AutoPing channel. The columns are "No.", "IP Address", "Action", "Assigned", and "Status".

No.	IP Address	Action	Assigned	Status
1	192.168.1.7	Cycle	Cabinet_1 Firewall	OK 0 <input type="button" value="Reset"/>
2	192.168.1.1	Cycle Once	Cabinet_4 Outlet2	OK 0 <input type="button" value="Reset"/>
3	192.168.1.99	Off-Follow	Group: All_Email_Servers	X 1 <input type="button" value="Reset"/>
4	0.0.0.0	None	Unassigned	OK 0 <input type="button" value="Reset"/>
5	0.0.0.0	None	Unassigned	OK 0 <input type="button" value="Reset"/>
6	0.0.0.0	None	Unassigned	OK 0 <input type="button" value="Reset"/>
7	0.0.0.0	None	Unassigned	OK 0 <input type="button" value="Reset"/>
8	0.0.0.0	None	Unassigned	OK 0 <input type="button" value="Reset"/>
9	0.0.0.0	None	Unassigned	OK 0 <input type="button" value="Reset"/>
10	0.0.0.0	None	Unassigned	OK 0 <input type="button" value="Reset"/>
11	0.0.0.0	None	Unassigned	OK 0 <input type="button" value="Reset"/>
12	0.0.0.0	None	Unassigned	OK 0 <input type="button" value="Reset"/>
13	0.0.0.0	None	Unassigned	OK 0 <input type="button" value="Reset"/>
14	0.0.0.0	None	Unassigned	OK 0 <input type="button" value="Reset"/>
15	0.0.0.0	None	Unassigned	OK 0 <input type="button" value="Reset"/>
16	0.0.0.0	None	Unassigned	OK 0 <input type="button" value="Reset"/>

AutoPing View

See Advanced Operation section page ?? for more about AutoPing

Command Line Interface

The Command Line Interface provides complete setup of all function of the iBootBar. Access the CLI either via the network interface using Telnet, or via the modem or serial port using a terminal emulation program. Some commands of the CLI require administrative rights. These are indicated in the table below.

Outlet Commands

Command	Description	Admin	Fact Def
get outlets	Returns the status of ALL the outlets the user has rights to. Displays all devices and outlets in a cluster configuration.	No	
get outlet <1-8>	Returns the status of the iBootBar. This command is for iBootBars not used in a cluster configuration. If used in a cluster, it is the same as device #1. The user must have rights to the selected outlet.	No	
set outlet <1-8> <on/off/cycle>	Sets the selected outlet to the selected state. The user must have rights to the selected outlet. This command is for iBootBars not used in a cluster configuration. If used in a cluster, it is the same as device #1	No	
get device <#1-#16/devname> outlet <1-8>	Returns the status of the select outlet on the selected iBootBar. Device is either the number of the device <#1 to #16> or the name of the device, as set. Number sign (#) required. The user must have rights to the selected outlet.	No	
set device <#1-#16/devname> outlet <1-8> <on/off/cycle>	Sets the selected outlet on the selected iBootBar to the selected state. The user must have rights to the selected outlet.	No	
set device <#1-#16/devname> outlet <1-8> name <name>	Sets the name of the selected outlet of the selected iBootBar. 20 characters max.	Yes	Outlet <#>
get device <#1-#16/devname> outlet <1-8> initial.state	Get or set the initial state of the selected outlet of the currently selected iBootBar. Initial state is the condition of the outlet when the iBootBar is powered up.	Yes	Last
set device <#1-#16/devname> outlet <1-8> initial.state <on/off/last>			

User Commands

Command	Description	Admin	Fact Def
get users	Return a list of all current users	Yes	
get user <username>	Returns the selected user's details	Yes	
add user <username>	Added a user to the root iBootBar's user table. 16 users maximum. 20 Characters max. Note: the new user's password will default to the same as the username. Users default to no rights to any outlets. Add user rights to outlets and groups.	Yes	
del user <username>	Deletes the selected user from the root iBootBar's user table	Yes	
ren user <username> <newname>	Renames the selected user in the root iBootBar's user table. 20 character max.	Yes	
set user <username> device <#1-#16/devname/all> outlet <1-8/all> <yes/no>	Sets the users right to the selected outlet on a specific device.	Yes	No Rights
set user <username> group <name> <yes/no>	Sets the user's rights to the selected group	Yes	No Rights
set user <username> role <admin/user>	Sets the user's roll.	Yes	User
set user <username> password <password> <confirm>	Sets the user's password. 20 characters max.	Yes	User's Name
set user <username> email <address>	Sets the user's email address for the root iBootBar to send alerts to. 64 characters max.	yes	
set user <username> sendmail <yes/no>	Enables or disables the user's receipt of email alerts.	Yes	No
set set user <username> pin <pin>	Sets the user PIN for DTMF control. -M models only. 4 – 10 digits.	Yes	

Device Commands

Command	Description	Admin	Fact Default
get devices / get all / get outlets	This command displays a list of connected devices, and their current status.	No	
get device <#1-#16/devname>	Get device information. Displays the device name, and all outlet names and current status	Yes	Dataprobe
set device <#1-#16 > name <name>	Set the name of the selected iBootBar. 20 characters max.		
get cycle	Get or set the cycle time in seconds.	No	10
set cycle <1-99>			
get delay	Get or set the delay time in seconds.	No	1
set delay <1-99>			
get console	Displays the current console configuration, Timeout and Baud Rate	Yes	
set console timeout <30-3600/disable>	Console can be set to automatically logout with no activity for 30 seconds to 1 hr in seconds, or disabled.	Yes	120
set console baudrate <400/4800/9600/19200/38400/57600/115200>	The baud rate of the serial port. 400,4800,9600,19200,38400,57600,115200 bps	Yes	115200
get modem	Gets the current settings of the modem. -M models only.	Yes	
set modem countrycode <contrycode>	Sets the modem country code. -M models only. See page 34 for a list of country codes.	Yes	181 (USA)
set device <0-16>	Get / Set the device ID for cluster applications. A device ID of 0 for single iBootBar applications. A device ID of 1 makes the unit a master, and a device ID of 2-16 make the iBB a remote in cluster configurations. These commands are only valid when directly connected to the iBootBar, rather than as remote units in a cluster.	Yes	0
get device			

<p>set unit <hwkey> device <2-16></p>	<p>Sets the ID of a remote device in cluster configurations. The hardware key <hwkey> is the last 2 bytes of the MAC address NO spaces, dashes or colons.</p>  <p>In this example, the <hwkey> is 38A2</p>	<p>Yes</p>	
<p>set factory defaults</p>	<p>Resets all parameters to their factory settings including the IP Address. Only available on the serial port. Confirmation is required. Note: This command can take up to 30 seconds to execute.</p>	<p>Yes</p>	
<p>logout</p>	<p>Ends the session</p>	<p>No</p>	
<p>reboot</p>	<p>Reboots the selected iBootBar. This will not change the status of the outlets.</p>	<p>Yes</p>	

Group Commands

Command	Description	Admin	Fact Def
get groups	Returns a list of the groups that the current user has rights to.	No	
get group <groupname>	Returns the details of the selected group	No	
set group <groupname> <on/off/cycle>	Controls the selected group	No	
add group <groupname>	Adds a new group. 20 characters max. Up to 8 groups maximum	Yes	
set group <groupname> device <#1-#16/devname/all> outlet <1-8/all> <yes/no>	Adds or deletes a specific outlet on a specific device from the selected group.	Yes	
ren group <groupname> <newname>	Renames the selected group. 20 characters max.	Yes	
del group <groupname>	Deletes the selected group.	Yes	

Network Commands

Command	Description	Admin	Fact Def
get network	Returns the network settings	Yes	
set ipmode <arp-ping/static/dhcp>	Set the IP Mode of the root iBootBar	Yes	ARP-Ping
set ipaddress <dotted decimal>	Set the root iBootBar's IP Address in dotted decimal	Yes	192.168.0.254
set subnet <dotted decimal>	Set the root iBootBar's subnet mask in dotted decimal	Yes	255.255.255.0
set gateway <dotted decimal>	Set the root iBootBar's gateway in dotted decimal	Yes	0.0.0.0

Web Server Commands

Command	Description	Admin	Fact Def
get web	Returns the root iBootBar's current web server settings	Yes	
set web enable <yes/no>	Enable or disable the root iBootBar's web server	Yes	Yes
set web port <1-65535>	Set the root iBootBar's web server's port. Web standard port is 80. If changed, access the iBootBar using http://xxx.xxx.xxx.xxx:<port> <i>Dataprobe recommends changing the web port on all iBootBars that are accessible from the internet.</i>	Yes	80
set web ssl <yes/no>	Enable or disable the root iBootBars web server's SSL capabilities.	Yes	No

Telnet Commands

Command	Description	Admin	Fact Def
get telnet	Returns the current settings of the root iBootBar's telnet server.	Yes	
set telnet enable <yes/no>	Enable or disable the root iBootBar's telnet server	Yes	Yes
set telnet port <1-65535>	Set the port of the root iBootBar's telnet server. <i>Dataprobe recommends changing the telnet port on all iBootBars that are accessible from the internet.</i>	Yes	23

Autoping Commands

Command	Description	Admin	Fact Def
get autoping <1-16>	Returns the settings and state of the selected autoping.	Yes	
set autoping <1-16> ipaddress <dotted decimal>	Set the IP address of the selected auto ping in dotted decimal.	Yes	0.0.0.0
set autoping <1-16> action <action>	Set the action of the selected auto ping. On-Follow, On-Latch, Off-Follow, Off-Latch, Cycle, Cycle-Once, or None.	Yes	None
set autoping <1-16> frequency <1-999>	Set the frequency of the selected autoping in seconds	Yes	10
set autoping <1-16> count <1-99>	Set the number of failures the select autoping requires before it triggers its action.	Yes	3
set autoping <1-16> device <name/#1-16> outlet <1-8>	Assign an AutoPing to either a device/outlet or group. Each AutoPing can be assigned to one or the other	Yes	
set autoping <1-16> group <name>		Yes	

Event Commands

Command	Description	Admin	Fact Def
get events	Returns a list of all pending events	Yes	
get event <eventname>	Returns the details of the selected event	Yes	
add event <eventname>	Creates a new event. Up to 16 events can be created. The default time and date will be the time and date that the event is added. The default action is none, and the default repeat is never	Yes	
dev event <eventname>	Deletes the selected event	Yes	
ren event <eventname> <new name>	Renames the event.	Yes	

set event <eventname> year <2007 – 2050>	Sets the year of the event	Yes	
set event < eventname> month <1-12>	Sets the month of the event	Yes	
set event <eventname> day <1-31>	Sets the day of the event	Yes	
set event <eventname> hour <0-23>	Sets the hour of the event.	Yes	
set event <eventname> minute <0-59>	Sets the minute of the event	Yes	
set event <enentname> action <on/off/cycle>	Set the event action	Yes	
set event <eventname > repeat < never / daily / weekly / monthly / annually>	Set the event repeat	Yes	
set event <eventname> control outlet <1-8>	Sets the outlet that will be controlled on the local device	Yes	
set event <eventname> control device <#1-#16/devname> outlet <1-8>	Assigns the event to either a device/outlet or group. Each event can be assigned to one or the other.	Yes	
set event <eventname> control group <groupname>		Yes	

Email Commands

Command	Description	Admin	Fact Def
get email	Returns the current setting of the root iBootBar's email client	Yes	
set email server <dotted decimal>	Set the IP address of an SMTP or ESMTP server,	Yes	0.0.0.0
set email address <return address>	Set the return address of the root iBootBar's email client.	Yes	0.0.0.0
set email username <username>	Set the user name for the mail server	Yes	0.0.0.0
set email password <password>	Set the password for the mail server	Yes	0.0.0.0

Time Commands

Command	Description	Admin	Fact Def
get time	Returns the current time and NTS settings	Yes	
set time server <ip address>	Sets the address of a NTS server for the root iBootBar to query.	Yes	129.6.15.29
set time usents <yes/no>	Enables or disables the root iBootBar's ability to connect to an NTS	Yes	Yes
set time zone <-12 to 12>	Set the time zone the root iBootBar is in.	Yes	-4
set time hour <0-23>	Sets the hour of the root iBootBar's RTC. Only valid if NTS is disabled.	Yes	
set time minute <0-59>	Sets the minute of the root iBootBar's RTC. Only valid if NTS is disabled.	Yes	
set time day <1-31>	Sets the day of the root iBootBar's RTC. Only valid if NTS is disabled.	Yes	
set time month <1-12>	Sets the month of the root iBootBar's RTC. Only valid if NTS is disabled.	Yes	
set time year <2006-20047>	Sets the year of the root iBootBar's RTC. Only valid if NTS is disabled.	Yes	

Firmware Upload Commands

Command	Description	Admin	Fact Def
get upload enable	Get or set the ability for the root iBootBar to accept a firmware upload.	Yes	
set upload enable		Yes	No

Advanced Operation

DTMF Control

Models with an internal modem <-M suffix> can be controlled from dial up connections using handset dialing tones (touch tones). Use of DTMF control requires a unique PIN number set for each user. This PIN is set using the command line interface and must be 4 to 10 digits long. Program a PIN code of 0 to disable a users ability to use DTMF control.

DTMF Call Sequence:

1. Dial the phone number connected to the iBootBar. Upon connection a prompt tone will be heard.
2. Enter the PIN followed by the # key. Upon successful entry, a ready tone will be heard. If no PIN or incorrect PIN is received, an error tone and new prompt tone will be issued. After three unsuccessful attempts, the iBootBar will hang up.
3. At the ready tone, enter an outlet number 1-8. The current status of that outlet will be stated in English: i.e. "one on" or "six off".
4. The # key is used to change the state of the outlet. The * key is used to reboot (or power cycle) the outlet for the time configured with the CLI command cycle time. The new status of the outlet is stated. If the * key is used, the iBootBar will also state 'begin' to indicate the reboot or cycle has begun.
5. A new prompt tone will indicate that new commands can be entered. While a reboot is in progress, additional outlets can be addressed and commanded.
6. The caller can hang up at any time to disconnect the call. Any reboots in progress will finish their cycle time as programmed.

NOTE: Not issuing a command for 5 seconds will cause the iBootBar to hang up.

Notes:

1. The only outlets that a caller has access to are determined by the CLI command set user outlet.
2. While prompts and voice responses are being played, the iBootBar will not process DTMF tones. Wait for the status and prompts to complete before issuing new commands
3. Address an outlet with a number command before entering a control command (# or *) if unsure which outlet is being addressed, send the outlet number again.
4. Factory Default user admin has default PIN 23646. Change to desired PIN if maintaining this account. Resetting to factory defaults will restore this user and PIN.

Timed Events

The iBootBar provides the ability to turn On, Off or Cycle outlets based on time and date. Each individual outlet or group can be set to operate a selected command at a specific time and date. The Timed Events are programmed thru the Control & Setup Utility or the CLI interface. Up to 16 events can be created.

Each event can be assigned to one outlet or group and repeated on a regular basis.

Administrative rights are required to set up and manage any event. To add an event, create the event, assign the event to a specific outlet or group and then configure the initial occurrence of the event, the action to be performed, and the repeat frequency, if desired.

To configure the timed events, use the following commands:

```
get events
get event <eventname>
add event <eventname>
dev event <eventname>
ren event <eventname> <new name>
set event <eventname> year <2007 – 2050>
set event <eventname> month <1-12>
set event <eventname> day <1-31>
set event <eventname> hour <0-23>
set event <eventname> minute <0-59>
set event <eventname> action <on/off/cycle>
set event <eventname> repeat < never / daily / weekly / monthly / annually>
set event <eventname> control outlet <1-8>
set event <eventname> control device <#1-#16/devname> outlet <1-8>
set event <eventname> control group <groupname>
```

AutoPing

The AutoPing feature allows iBootBar to automatically detect failed equipment and perform a timed reboot or other power control function (like turning on an indicator or siren). You set any IP address to be periodically pinged. When iBootBar no longer detects a response from the address, the programmed power control function is actuated.

Up to 16 AutoPing channels are available and each AutoPing can be assigned to an outlet or group. In cluster configurations, any of the 16 AutoPing channels can be assigned to any outlet on any device in the cluster.

Ping Address Enter the IP address of the device to be pinged.

Ping Frequency Enter 1 to 999 seconds. The ping will go out to the selected device this often.

Fail Counter Enter 1-99 times the ping needs to fail consecutively before the selected action is taken. When the fail count has been reached, the AutoPing action will be triggered.

Action: Select from

None	AutoPing not used
On – Latch	Upon triggering, iBootBar will power on the assigned outlet and remain so until changed via the web or telnet/serial interface.
On – Follow	Upon triggering, iBootBar will power on the assigned outlet. When the ping response returns, iBootBar will power the off the outlet
Off – Latch	Upon triggering, iBootBar will power off the assigned outlet and remain so until changed via the web or telnet/serial interface.
Off – Follow	Upon triggering, iBootBar will power off the assigned outlet. When the ping response returns, iBootBar will power the outlet on.
Cycle	Upon triggering, iBootBar will cycle the power to the assigned outlet. iBootBar will wait the Ping Frequency x Fail Count; if the response does not return, the power will be recycled again. This will continue until the ping response returns or AutoPing is turned off. Make sure your AutoPing frequency x Fail Count is longer than the time required to reboot your device.
Cycle Once	Upon triggering, iBootBar will cycle power one time. It will not cycle again automatically until the ping response returns and is lost again.

Web Operation:

With AutoPing operational, the AutoPing Status page will display the current status of this feature. The status will be OK to indicate that iBootBar is receiving responses to the ping, or that the fail counter has not yet been exceeded.

If the fail count has been exceeded, the status will change to Triggered. The counter will indicate the number of times the AutoPing has been triggered since the last reset. Click on the Reset button to reset the counter.

CLI Operation and Setup:

To view the status of any of the AutoPing channels, issue the `get autoping <1-16>` command.

```
iBootBar > get autoping 1
IP Address: 192.168.1.7
Action: Cycle
Frequency: 30
Count: 3
Outlet: Cabinet_1 - Firewall
Status: OK
OK
iBootBar >
```

To configure the AutoPing, use the following commands:

```
set autoping <1-16> ipaddress <dotted decimal>
set autoping <1-16> action <action>
set autoping <1-16> frequency <1-999>
set autoping <1-16> count <1-99>
set autoping <1-16> device <name/#1-16> outlet <1-8>
set autoping <1-16> group <name>
```

SSL Security

The iBootBar can provide Secure Socket Layer (SSL) encryption on the web interface. Enable this feature using the `set web ssl yes` command from the Telnet / Serial interface.

Certificate Upload Utility

The Certificate Utility (CUU.exe) is designed to create and distribute Secure Socket Layer (SSL) certificates to iBootBars and the PCs that communicate them. Although the iBootBar comes from the factory with a certificate installed, this certificate common name is Dataprobe iBB, and will generate a warning message when connecting to the iBootBar when using SSL. For most customers, this error message can be easily ignored and secure connection to the iBootBar continues. For customers with special circumstances, the CU was designed to facilitate creation and distribution of SSL Certificates tailored to a specific iBootBar, eliminating the error message entirely. There are two methods that can be used to create and distribute the certificates

1. Self Signed Certificates. A Self-signed certificate is the most common approach. In this approach, the CU generates multiple certificates, each unique and based on the IP address, or DNS name of each iBootBar. The CU also provides the means to install the certificate on the iBootBar, making it easy to generate and distribute. Upon initial connection to the iBootBar, the user will be offered an opportunity to install the certificate from the iBootBar. This is done once for each browser on the PC and each iBootBar.

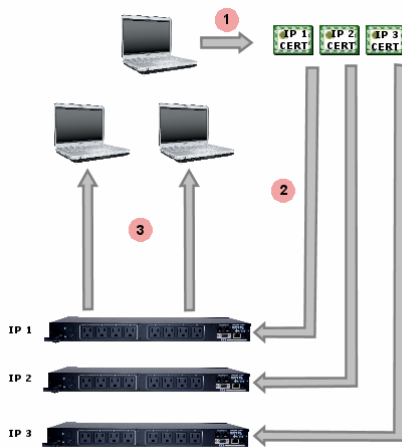

Self Sign Method

- Step 1:** Using the CU, create one unique Certificate based on the IP Address of each iBootBar.
- Step 2:** Use the CU to upload the Certificates to each iBoot Bar
- Step 3:** Upon connecting to the iBootBar, each PC accepts the certificate installed in the iBootBar.

2. Root Certificate Authority. The Root Certificate Authority method pre installs the certificates required in both the PC and the iBootBar. This eliminates the need for accepting the certificate from each iBootBar on each PC. The Root Certificate is generated and installed in each PC prior to communication with the iBootBar. The Root Certificate also is used, along with the IP address or domain of the iBootBar, to generate the certificates that are installed in the iBootBar.

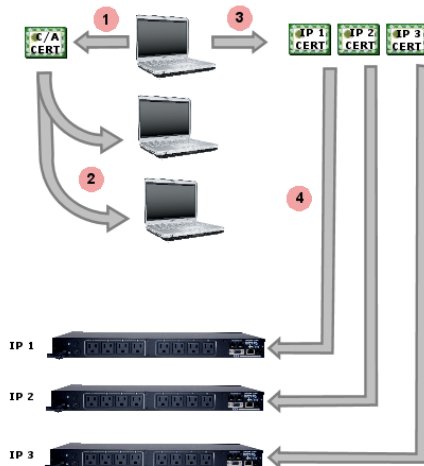

Root Certificate Authority Method

- Step 1:** Create A Root Certificate Authority (CA) using the Certificate Upload Utility (CU).
- Step 2:** Install the CA into any PCs that need to communicate with the iBootBars.
- Step 3:** Create certificates for each iBootBar using the CU. Each certificate is unique and based on the C/A and the iBootBars IP Address or domain name.
- Step 4:** Install the certificate into the iBootBar(s) using the CU.

The CUU is available on the ibootbar CD or from the Dataprobe website: <http://Dataprobe.com/ibootbartools.html>
Complete instructions for use of the CUU are included with the software.

Email Notification

Email can be automatically sent for outlet changes, AutoPing triggers and current alarms. The necessary parameters for email are set using the Telnet / Serial Interface:

```
set email server <dotted decimal>
set email address <return address 64 char max>
set email username <user name 128 char max>
set email password <password 128 char max>
```

Each user is assigned an email address and email can be turned on or off for that user:

```
set user <name> email <email address 64 char max>
set user <name> sendmail <yes/no>
```

Emails generated by iBootBar will display the device, outlet(s) command along with the user and method of control.

Examples:

```
Subject: Power Switch: Cabinet_1
Date : Mon, 7 Jul 2008 09:41:00 -
        0500
From : <iBootBar@dataprobe.com>
To : <networkadmin@yourco.com>
```

```
Location: Cabinet_1
Outlets: 5 Server_B
Command: Cycle
User: admin
Source: Telnet
```

```
Subject: Power Switch: Cabinet_3
Date : Mon, 7 Jul 2008 09:46:00 -
        0500
From : <iBootBar@dataprobe.com>
To : <networkadmin@yourco.com>
```

```
Location: Cabinet_1
Outlets:
3 Router_A
6 Router_B
Command: Off
User: admin
Source: Web
```

SNMP

Up to four SNMP managers can be set. Each manager will receive Trap notifications for outlet changes, autoping and current alarms. Set the SNMP manager IP addresses using the `set snmp <n> ipaddress <dotted decimal>` command. Enable or Disable SNMP for any manager with the `set snmp <n> enable <yes/no>` command. The MIB is available on the distribution CD, or at <http://Dataprobe.com/ibootbartools.html>

The iBootBar also supports the following elements of MIB-II

```
mgmt [1.3.6.1.2]
  |
  -> [ 1] -BR- mib-2
      |
      -> [ 1] -BR- system
          |
          -> [ 1] *RO* DisplayString      sysDescr
          -> [ 2] *RO* OBJECT IDENTIFIER  sysObjectID
          -> [ 3] *RO* TimeTicks           sysUpTime
          -> [ 4] *RW* DisplayString      sysContact      Truncated to 128 Char
          -> [ 5] *RW* DisplayString      sysName          Truncated to 128 Char
          -> [ 6] *RW* DisplayString      sysLocation      Truncated to 128 Char
          -> [ 7] *RO* INTEGER            sysServices
```

Firmware Upgrades

The iBootBar can be upgraded via the network if the upload feature has been enabled using the `set upload enable yes` command on the console interface. To upgrade the iBootBar download the latest version of the firmware and upgrade utility from the Dataprobe website. <http://Dataprobe.com/ibootbartools.html>

Password Recovery

Holding the reset button on the front panel of the iBootBar for 5 seconds or longer will initiate a password recovery mode. Once the reset button is released, the user has 30 seconds to log in to the CLI using the username `admin` and password `admin`. Upon accessing the CLI, change the username and password for User 1 as desired.

iBootBar Setup and Control Utility

The iBootBar Setup and Control Utility is designed to facilitate installation, configuration and management of one or more iBootBars, Dataprobe's remote controlled power strip. With the Setup Utility, users can:

1. Automatically discover multiple iBootBars on a local network
2. Adding additional iBootBars, not on the local network
3. Download existing configurations from installed iBootBars
4. Save existing configurations for later use or as backup
5. Open saved configurations for change management
6. Clone saved configurations for replication of similar configurations in multiple iBootBars
7. Upload modified configurations to iBootBars
8. Control Power Outlets on one or more iBootBars throughout the network

The iBootBar Setup & Control Utility works securely through the network connection between a PC running Windows 98 or higher, and the iBootBar. Administrator rights are required on the iBootBar to properly use the Utility. All communication between the program and the iBootBars is encrypted using AES.

Complete documentation on the use of the Setup & Control Utility are supplied with the software.

The iBootBar Setup and Control Utility is available on the iBootBar CD or from Dataprobe website at <http://Dataprobe.com/ibootbartools.html>

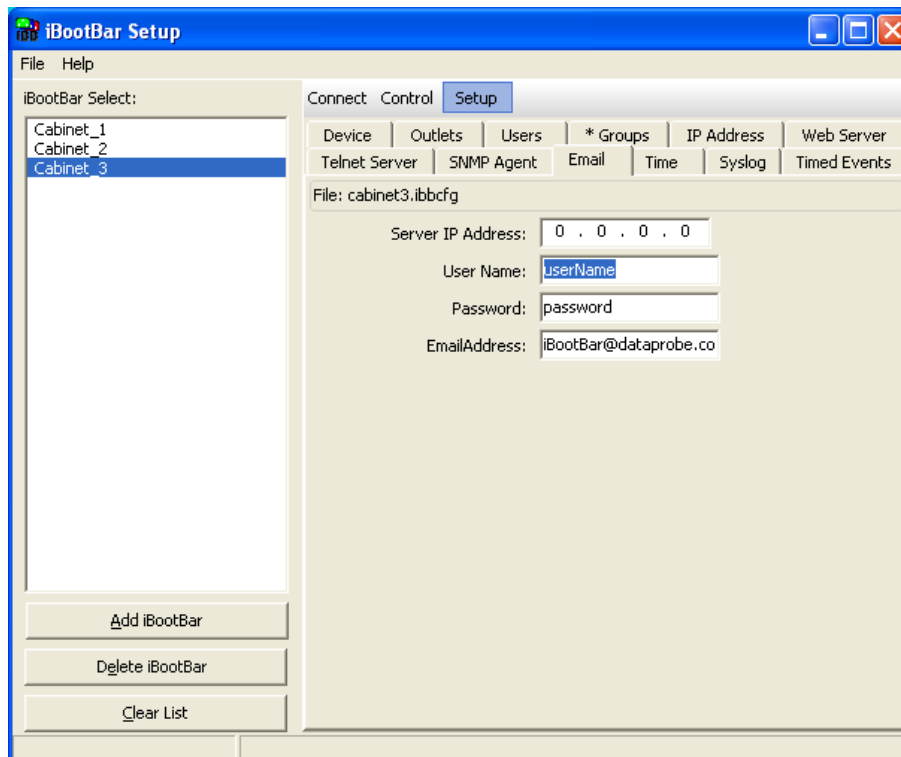

Specifications

Physical:

Height: 2"
Width: 5"
Depth: 7"
Weight: 2 lbs.

Environmental:

Temperature
Operating: 0 to 40° C
Storage: -10 to 85° C
Relative Humidity: 0 to 95%
Non-Condensing

DC

Input: 2 Position Pluggable Screw Terminal
Voltage Range: Auto Sensing 5 – 30VDC
Switched Outputs: Eight, 2 Position Pluggable Screw Terminal
Current Capacity: 8 A. Max at 5-30VDC Combined Total
5 A Max at 5-30 VDC per Outlet.

Compliance

CE: Directives 89/336/EEC, 92/31/EEC and 93/68/EEC
EN 55022: 1998 Class B
FCC: Part 15 Class B

Network

10/100 Ethernet. Web, Telnet, SNMP.
Port Assignable for Web and Telnet. SSL on Web control.
Serial Port. 115,200 bps. Command Line Interface
Internal Modem Version. V.92 and below. Approved in 50 Countries
Supports data and DTMF tone control (with voice response)

Compliance Statements

FCC Part 15 Regulation

This equipment has been tested and found to comply with the limits for a Class A digital device, pursuant to Part 15 of the FCC rules. These limits are designed to provide reasonable protection against harmful interference in a residential installation. This equipment generates, uses, and can radiate radio frequency energy, and if not installed and used in accordance with the instructions, may cause harmful interference to radio communications. However, there is no guarantee that interference will not occur in a particular installation. If this equipment does cause harmful interference to radio or television reception, which can be determined by turning the equipment off and on, the user is encouraged to try to correct the interference by one or more of the following measures:

- Reorient or relocate the receiving antenna.
- Increase the separation between the equipment and receiver.
- Plug the equipment into an outlet on a circuit that is different from the one used by the receiver.
- Consult the dealer or an experienced radio/TV technician for help.

This device complies with Part 15 of the FCC rules. Operation of this device is subject to the following conditions: (1) This device may not cause harmful interference, and (2) this device must accept any interference that may cause undesired operation.

WARNING: Changes or modifications to this unit not expressly approved by the party responsible for compliance could void the user's authority to operate the equipment

EMC, Safety, and R&TTE Directive Compliance

The CE mark is affixed to this product to confirm compliance with the following European Community Directives:

- Council Directive 89/336/EEC of 3 May 1989 on the approximation of the laws of Member States relating to electromagnetic compatibility;
And
- Council Directive 73/23/EEC of 19 February 1973 on the harmonization of the laws of Member States relating to electrical equipment designed for use within certain voltage limits;
and
- Council Directive 1999/5/EC of 9 March on radio equipment and telecommunications terminal equipment and the mutual recognition of their conformity.

Industry Canada

This Class A digital apparatus meets all requirements of the Canadian Interference-Causing Equipment Regulations.

Cet appareil numérique de la classe AB respecte toutes les exigences du Règlement Canadien sur le matériel brouilleur.

This product meets the applicable Industry Canada technical specifications

Modem Certifications

The following countries have certified the internal modem. In order to comply with local regulations, the countrycode must be set to the country of installation. To set the modem for the desired country use the CLI command `set modem countrycode <countrycode>`. Use the `get modem` command to display the current country setting.

Note: Use of the wrong countrycode violates local laws and the warranty of this product.

Country	countrycode
Argentina	07
Australia	09
Austria	253
Belgium	253
Brazil	22
Bulgaria	253
Canada	181
Chile	153
China	181
Cyprus	253
Czech Republic	253
Denmark	253
Estonia	253
Finland	253
France	253
Germany	253
Greece	253
Hong Kong	153
Hungary	253
Iceland	253
India	153
Indonesia	153
Ireland	253
Israel	181
Italy	253
Japan	00
Korea	181

Country	countrycode
Latvia	253
Liechtenstein	253
Lithuania	253
Luxembourg	253
Malaysia	108
Malta	253
Mexico	181
Netherlands	253
New Zealand	126
Norway	253
Philippines	181
Poland	253
Portugal	253
Russia	253
Singapore	156
Slovak Republic	253
Slovenia	253
South Africa	159
Spain	253
Sweden	253
Switzerland	253
Taiwan	254
Thailand	181
Turkey	253
United Kingdom	253
United States	181

SNMP MIB

Download at <http://dataprobe.com/iBootBarTools.html>

enterprises [1.3.6.1.4.1]

```

|
-> [1418] -MI- dataprobe
|
-> [ 4] -BR- iBootBarAgent
|
-> [ 1] -BR- systemSettings
|
-> [ 1] *RW* DisplayString      deviceName
-> [ 2] *RW* INTEGER(Enum)      ipMode
-> [ 3] *RW* DisplayString      ipAddress
-> [ 4] *RW* DisplayString      subnetMask
-> [ 5] *RW* DisplayString      gateway
-> [ 6] *RW* INTEGER(Enum)      webEnable
-> [ 7] *RW* Integer32          webPort
-> [ 8] *RW* INTEGER(Enum)      sslEnable
-> [ 9] *RW* INTEGER(Enum)      telnetEnable
-> [10] *RW* Integer32          telnetPort
-> [11] *RW* INTEGER(Enum)      updateEnable
-> [12] *RW* Integer32          cycleTime
-> [13] *RW* Integer32          delayTime
|
-> [ 2] -TB- snmpManagerTable
|
-> [ 1] -TE- snmpManagerEntry
|
-> [ 1] *RO* Integer32          snmpManagerIndex
-> [ 2] *RW* DisplayString      snmpManagerIPAddress
-> [ 3] *RW* INTEGER(Enum)      snmpManagerEnable
|
-> [ 3] -TB- outletTable
|
-> [ 1] -TE- outletEntry
|
-> [ 1] *RO* Integer32          outletIndex
-> [ 2] *RW* OCTET STRING       outletName
-> [ 3] *RO* INTEGER(Enum)      outletStatus
-> [ 4] *RW* INTEGER(Enum)      outletCommand
-> [ 5] *RO* INTEGER(Enum)      outletAPStatus
|
-> [ 4] -BR- info
|
-> [ 1] *RO* Integer32          currentLC1
-> [ 2] *RO* Integer32          currentLC2
-> [ 3] *RO* INTEGER(Enum)      numberOfLineCords
|
-> [ 5] -NT- outletChange
-> [ 6] -NT- autoPingFailed
-> [ 7] -NT- currentAlarm
-> [ 8] -NT- emailError
-> [ 9] -NT- autopingTrigger
-> [10] -NT- autopiResponding

```

Legend :

AC - Agent Capabilities
 AN - Accessible for Notify
 BR - Branch
 MC - Module Compliance
 MI - Module Identity
 NA - Not Accessible
 NG - Notification Group
 NT - Notification Type
 OG - Object Group
 OI - Object Identity
 RO - Read Only
 RC - Read Create
 RW - Read Write
 TB - Table
 TE - Table Entry

Technical Support, Returns and Warranty

Dataprobe Technical Support is available 8:30AM to 5:30PM ET to assist you in the installation and operation of this product. To obtain Technical Support call 201- 934-5111, or Email us at tech@dataprobe.com. Please have the following information available when you call:

- Model of Product
- Lot and Version Numbers
- Data of Purchase
- Name of Seller (if other than Dataprobe)

If you purchased this product through an Authorized Dataprobe Reseller, you should contact them first, as they may have information about the application that can more quickly answer your questions.

WARRANTY

Seller warrants this product, if used in accordance with all applicable instructions, to be free from original defects in material and workmanship for a period of One Year from the date of initial purchase. If the product should prove defective within that period, Seller will repair or replace the product, at its sole discretion.

Service under this Warranty is obtained by shipping the product (with all charges prepaid) to an authorized service center. Seller will pay return shipping charges. Call Dataprobe Technical Service at (201) 934-5111 to receive a Return Materials Authorization (RMA) Number prior to sending any equipment back for repair. Include all cables, power supplies and proof of purchase with shipment.

THIS WARRANTY DOES NOT APPLY TO NORMAL WEAR OR TO DAMAGE RESULTING FROM ACCIDENT, MISUSE, ABUSE OR NEGLIGENCE. SELLER MAKES NO EXPRESS WARRANTIES OTHER THAN THE WARRANTY EXPRESSLY SET FORTH HEREIN. EXCEPT TO THE EXTENT PROHIBITED BY LAW, ALL IMPLIED WARRANTIES, INCLUDING ALL WARRANTIES OF MERCHANT ABILITY OR FITNESS FOR ANY PURPOSE ARE LIMITED TO THE WARRANTY PERIOD SET FORTH ABOVE; AND THIS WARRANTY EXPRESSLY EXCLUDES ALL INCIDENTAL AND CONSEQUENTIAL DAMAGES.

Some states do not allow limitations on how long an implied warranty lasts, and some states do not allow the exclusion or limitation of incidental or consequential damages, so the above limitations or exclusions may not apply to you. This warranty gives you specific legal rights, and you may have other rights which vary from jurisdictions to jurisdiction.

WARNING: The individual user should take care to determine prior to use whether this device is suitable, adequate or safe for the use intended. Since individual applications are subject to great variation, the manufacturer makes no representation or warranty as to the suitability of fitness for any specific application.

Dataprobe Inc.