

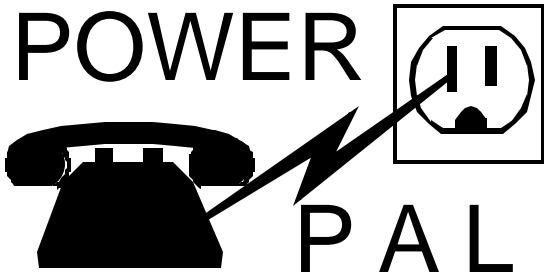

**PowerPal-EXP**  
**PP-NC-03, PP-NC-03-220**  
 Expandable Power Controller  
 # 1410014, 1410019



PowerPal EXP uses a dial telephone line to remotely control A/C power. The user can turn power ON, OFF or Power Cycle (Reboot) by entering DTMF digits using an ordinary tone dial phone. The phone line connected to PAL can also be used by other equipment in a normal manner after control of power. With one phone call, you can power up, down or reboot equipment then ring the telephone device connected to PowerPal EXP's Extension port. Power control can be expanded to two independent outlets with the addition of a K-103 power switch module.

Pal works by listening for dialing tones (DTMF) after it answers a call. If these tones are heard, Pal will respond with a prompt and the user can access either of the two outlets. Power status on either outlet information is provided by tones and additional dialing tones control the power. Once power control is completed, the device on Pal's Extension may (or may not) be rung.

Three call answering modes, security features and power control options make PowerPal EXP both easy to use and very flexible.

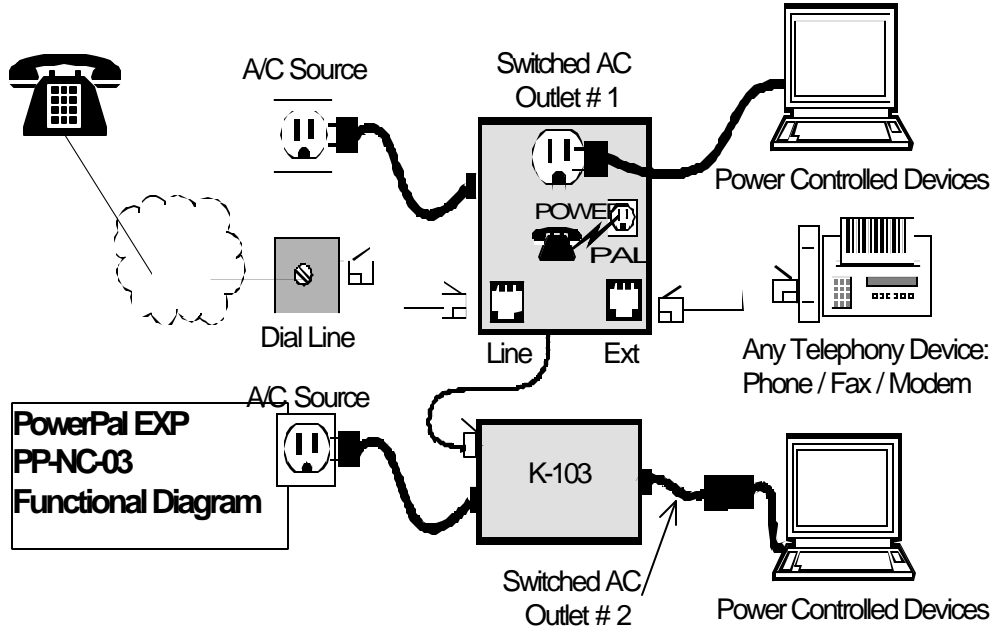

Doc Ref: PP-NC-03\_1410014\_V021024D

Technical Support Hotline: (201) 967-8788



Technical Support: 201-934-5111  
 Main: 201-934-9944

tech@dataprobe.com  
 Website: dataprobe.com

## IMPORTANT SAFETY INSTRUCTIONS

When using this product, basic safety precautions should always be followed to reduce the risk of fire, electric shock, and injury to persons, including the following:

1. Read and understand all instructions.
2. Follow all warnings and marked on the product.
3. Unplug this product from the wall outlet before cleaning. Do not use liquid cleaners or aerosol cleaners. Use a damp cloth for cleaning.
4. Do not use this product in an outdoor environment or near water, for example, near a bath tub, wash bowl, kitchen sink, or laundry tub, in a wet basement, or near a swimming pool.
5. Do not place this product on an unstable cart, stand, or table. The product may fall, causing serious damage to the product.
6. Slots and openings in this product and the back or bottom are provided for ventilation to protect it from overheating, these openings must not be blocked or covered. The openings should never be blocked by placing the product on the bed, sofa, rug, or other similar surface. This product should never be placed near or over a radiator or heat register. This product should not be placed in a built-in installation unless proper ventilation is provided.
7. This product should be operated only from the type of power source indicated on the marking label. If you are not sure of the type of power supply to your home, consult your dealer or local power company.
8. This product is equipped with a three wire grounding type plug, a plug having a third (grounding) pin. This plug will only fit into a grounding type power outlet. This is a safety feature. If you are unable to insert the plug into the outlet, contact your electrician to replace your obsolete outlet. Do not defeat the safety purpose of the grounding type plug. Do not use a 3-to-2 prong adapter at the receptacle; use of this type adapter may result in risk of electrical shock and/or damage to this product.
9. Do not allow anything to rest on the power cord. Do not locate this product where the cord will be abused by persons walking on it.
10. Do not overload wall outlets and extension cords as this can result in the risk of fire or electric shock.
11. Never push objects of any kind into this product through slots as they may touch dangerous voltage points or short out parts that could result in a risk of fire or electrical shock. Never spill liquid of any kind on the product.
12. To reduce the risk of electrical shock, do not disassemble this product, but take it to a qualified serviceman when some service or repair work is required. Opening or removing covers may expose you to dangerous voltages or other risks. Incorrect re-assembly can cause electric shock when the appliance is subsequently used.
13. Unplug this product from the wall outlet and refer servicing to qualified service personnel under the following conditions:
  - a) When the power supply cord or plug is damaged or frayed.
  - b) If liquid has been spilled into the product.
  - c) If the product has been exposed to rain or water.
  - d) If the product does not operate normally by following the operating instructions. Adjust only those controls, that are covered by the operating instructions because improper adjustment of other controls may result in damage and will often require extensive work by a qualified technician to restore the product to normal operation.
  - e) If the product has been dropped or has been damaged.
  - f) If the product exhibits a distinct change in performance.
14. Avoid using a telephone (other than a cordless type) during an electrical storm. There may be a remote risk of electric shock from lightning.
15. Do not use the telephone to report a gas leak in the vicinity of the leak.
16. Do not exceed the maximum output rating of the auxiliary power receptacle.

## POWER COMMAND SEQUENCE

A call placed to PowerPal EXP is answered based on one of three programmed answer modes. In all cases, PAL answers the call and listens for wake-up or security codes. If these codes are received, PAL will respond with a ready prompt and allow additional codes to control the power status of the outlets. When power control is complete, the caller has the option of ringing the extension connected to PAL. Once the Extension is rung, no additional control codes are accepted. The call sequence is:

**Answer → Power Control → Extension Ring → Call Complete**

## CALL ANSWER MODES

PowerPal EXP has three ways it can answer an incoming call. The mode you select will depend on who is usually calling PowerPal EXP and how secure you want the power control to be. In all cases, the number of rings before PowerPal EXP answers the call, additional security codes and how the call is passed on to the Extension Port are programmable. For any of these modes, PowerPal EXP is ready to control power when you hear the three short “Ready” beeps.

### **Normal Answer Mode**

In this mode, PowerPal EXP will answer the call and generate a ‘Ringback’ signal. This signal is like the one you hear when the phone company is ringing Pal. During the quiet times of the ringback, PAL listens for the Security Code (if set) or any dialing digit if not set. If, after two ringbacks, no tones are heard, Pal will ring the Extension Port. This is the default mode.

*Use the Normal Answer Mode if: Voice or Fax calls are being made to the device on Pal’s Extension Port and you don’t want the caller to know that Pal is there.*

### **Answer and Prompt Mode**

Pal answers the call and issues a prompt to the caller. If a Security Code is set, the prompt is one long beep. Enter the Code. Pal will respond with the “Ready” prompt (three short beeps). If no security code Pal immediately sends the three short “Ready” prompts. If no control tones are received in 6 seconds, Pal will ring the Extension.

*Use the Answer and Prompt Mode if: You want a more secure line or you want to know exactly when to put in the power control codes.*

### **Quiet Answer Mode**



Pal will answer the call and be quiet for 10 seconds. During this time, enter Security Code (if set) or any dialing digit if no security code is set. If none are received within 10 seconds, Pal will ring the Extension.

*Use the Answer and Quiet Mode if: You want secure control of power and the shortest time before the extension is rung.*

## POWER CONTROL

The A/C power is controlled by a few simple codes sent to Pal. In all cases, Pal responds with tones to confirm commands and to report the current status of the power. If invalid codes are sent, Pal responds with a low 'Error' tone. Power can only be controlled on calls placed to Pal. During outgoing calls, Pal is totally transparent, allowing any phone numbers to be dialed without risk of accidental power control.

### Select Outlet



Once PowerPal EXP is ready, it will send a "Ready" prompt (three short beeps). The caller has 10 seconds to enter a  or  to select the desired outlet.

Pal will respond with the current power status:

One Beep = Power OFF

Two Beeps = Power ON

Once the current status is reported the caller can control the power. Power can either be changed On or Off, or a Power Reset can be done.

The caller can switch any time between Outlets 1 and 2. Each time  or  is selected, the current status of the outlet is reported.

### Change Power

To Change Power                      Enter: 

This Toggles power from On to Off or Off to On. Pal will respond with the new status. Power On (Two Beeps), Power Off (One Beep). The Power Change command can be entered as many times as necessary.

### Power Cycle

To Power Cycle                      Enter: 

Power Cycle will change the power status for a preset time. The length of the Cycle is user programmable (5-45 sec.). When Power Reset is commanded, Pal first reports status at the start of the pulse, then again after the preset time. This feature can be used to do a power reset (from On to Off to On) or a momentary On (Off to On to Off).

## EXTENSION RING

The Extension Port can be accessed at any time after Pal gives the "Ready" prompt by simply pressing the  key. This will cause the Pal to ring the Extension Port. If the device on the extension does not answer, Pal will terminate the call. The number of rings Pal allows to the extension is user programmable (1-6 rings).

## CALL COMPLETION

Once Pal rings the Extension Port, it continues to monitor the call. When the call is completed, Pal will hang-up the phone line and wait for the next call. Pal's Power setting will remain in its last position. Optionally, Pal can be set to automatically turn power off on Outlet 1 after a preset time (0 to 90 seconds). Use this setting to automatically shut down equipment when the call is complete. A typical application would be to turn off a PC when the modem call to that PC is finished. If the power is off when the call is terminated, this setting is ignored.

## SECURITY

Additional security can be added to Pal's power control and extension ringing features. With security enabled, an additional code is required before gaining access to the power control. Once the code is received, Pal will respond with the Ready prompt (three short beeps). The security code can be from one to six digits long.

The security feature can be set for just power control, or both the power control and extension ring functions.

When set for Power Only; all callers have unrestricted access to the extension, while a code is required for power control. When set for Both Power and Extension; security code is required for all Pal functions.

If an incorrect security code is entered, Pal will send a low Error tone and wait for a second attempt. If the second attempt is incorrect, or if no security code is entered at all, Pal will ring the extension (Power Only), or hang up (Power and Extension Secure).

## OPERATION SUMMARY

Command	Code	Remarks
Select Outlet	1 or 2	Pal responds with power status 1 Beep = Off, 2 = On Power does not change.
Power Toggle	#	Power Changes and new status is reported
Power Cycle	*	Power is Cycled for preset time. (Programmable from 5 to 45 seconds).

## PROGRAMMING

**Warning:** Disconnect all equipment from PowerPal EXP's A/C receptacle when programming Pal.

All user programmable settings are set using a tone telephone connected to Pal's Extension Port (EXT). Settings are stored in non-volatile memory and will not be lost when power is removed from Pal.

To enter the Programming Mode: disconnect the telephone line connected to Pal, pick up the phone handset (go off-hook) and enter **#\*#** Pal responds with two Beeps to confirm programming mode.

### Programming Pal

Each setting for Pal has a number code. Once in the programming mode, each feature is set by entering the feature number, then the setting for that feature, followed by a **\*** to confirm entry and set the new value.

**Feature Number → New Value → \***

This can be repeated as many times as necessary. It is not necessary to program the features in order. If an incorrect entry is made, Pal will send the low Error tone. Reenter the number, value and star to continue.

To end the programming mode, hang up the phone and reconnect the dial line to Pal.

### Answer Mode

- 6 1★ Normal Answer Mode ← Factory Setting
- 6 2★ Answer and Prompt
- 6 3★ Answer and Quiet

### No. of Rings before Pal Answers the Call

- 2 n★ n = Number of rings (1-6) Factory Setting = 1

### No. of Rings to the Extension before Pal Terminates the Call

- 7 n★ n = Number of rings (1-6) Factory Setting = 6

### Power Reset Time

- 9 n★ Set in 5 second increments Factory Set =10 sec.  
(n = 1-9 for 5 to 45 seconds)

### Call Completion

- 4 1★ Power on Outlet 1 remains in current state on call completion ← Factory Setting
- 4 0★ Power Down on Outlet 1 on call completion after delay set below
- 8 n★ Call Completion Power Down Delay  
Delay is set in 10 second increments  
(n = 1-9 for 10 to 90 seconds)

### Security

- # c★ Security set to code 'c' (1 to 6 digits)
- 5 0★ Security Off ← Factory Setting
- 5 1★ Power Only Secure
- 5 2★ Power and Extension Secure

## PROGRAMMING SUMMARY

Feature	Code	Options
Enter Programming Mode	##	Responds with two Beeps
Answer Mode	6 n ★	1= Normal Answer (ring back) 2= Answer & Prompt 3= Answer & Quiet
Pal Answers Call	2 n ★	n = Number of Rings (1 - 6)
Pal Rings Extension	7 n ★	n = Number of Rings (1 - 6)
Power Reset Time	9 n ★	n = 1 - 9 five second increments
Call Completion Outlet 1 Only	4 1 ★ 4 0 ★ 8 n ★	Power remains in last state Power Shutdown Outlet 1 after delay Auto Shutdown Delay n = 1 - 9 ten second increments.
Security	# c ★ 5 0 ★ 5 1 ★ 5 2 ★	Security set to code 'c' (1 to 6 digits) Security Off Power Only Secure Power and Extension Secure

## INSTALLATION

### Power Source

**Model PP-NC-03 #1410014** 120VAC 60 Hz. NEMA 5-15 Line cord and outlet

**Model PP-NC-03-220 #1410019** 220VAC 50-60Hz IEC320 Line cord and outlet

### Power Controlled Device

Connect the device to be power controlled to Pal's A/C outlets. Make sure that the total current of the devices connected does not exceed 10 Amps.

### Extension Device

Connect any device that would normally be used on the telephone line to PowerPal's modular jack marked EXT.

### Phone Line

Connect the RJ11 Jack marked LINE to the telephone line.

### Expansion Module: K-103 Item# 1420016

For two outlet control, connect the control jack on the K-103 power switch to the PowerPal EXP using the modular cable exiting from the rear of the PowerPal EXP. Connect the equipment to be controlled by Outlet 2 to the switched outlet on the K-103 using the jumper cord provided. **Caution: Make sure the voltage selector switch on the K-103 is set to the correct AC voltage, 115V or 230V.** Attach the AC INPUT connector on the K-103 to an AC power source using the line cord provided. The led indicator located near the switched outlet will turn on when the K-103 expansion module is activated by the PowerPal EXP power switch.

## FUSE REPLACEMENT

In the event that the device connected to Pal fails to power up when commanded to, inspect the fuse located at the rear of PowerPal EXP. Before removing the fuse, disconnect Pal from its A/C source. Then remove the fuse by rotating the top of the fuse holder with a screwdriver.

If the fuse is visibly damaged, replace it with the same type and rating 250V 10 Amp fuse (5 X 20 mm).

## GENERAL SPECIFICATIONS

### Electrical

**Model PP-NC-03 #1410014**

120 VAC 60 Hz. , 10 Amps maximum switching capacity

Power Input: NEMA 5-15P Linecord

Switched Outlet: NEMA 5-15R Receptacle

**Model PP-NC-03-220 #1410019**

220 VAC 50-60Hz, 10 Amps maximum switching capacity

Power Input: IEC 320 C14 Line Cord

Switched Outlet: IEC 320 C13 Receptacle

**Total power** = Connected load + 60 Watts

### Physical

Table top unit - UL 94V-0 rated plastic

Dimensions - 8" x 6.25" x 2.75"

Weight - 4.0 lbs.

## FCC REGISTRATION INFORMATION

**Power Pal FCC registration number: DNMUSA23923-OT-N REN: 0.4B**

This equipment complies with Part 68 of the FCC rules. On the bottom of this unit is a label that contains, among other information, the FCC registration number and ringer equivalence number (REN) for this equipment. If requested, this information must be provided to the telephone company. REN is used to determine the quantity of devices on which may be connected to the telephone line. Excessive RENs on the telephone line may result in the devices not ringing in response to an incoming call. In most, but not all areas, the sum of RENs should not exceed five (5.0). To be certain of the number of devices that may be connected to the line, as determined by the total RENs, contact the local telephone company.

This equipment is designed for use with USOC registered jack RJ11. It is intended for single line use, and may not be used on public coin phone service provided by the telephone company. Connection to party line service is subject to state tariffs (contact state public utility commission, public service commission or corporation commission for information). An FCC compliant telephone cord and modular plug is provided with this equipment. This equipment is designed to be connected to the telephone network or premises wiring using a compatible modular jack which is Part 68 compliant. See Installation section for details.

If Power Pal causes harm to the telephone network, the telephone company will notify you in advance that temporary discontinuance of service may be required. If advance notice is not practical, the telephone company will notify the customer as soon as possible. Also, you will be advised of your right to file a complaint with the FCC if you believe it is necessary. The telephone company may make changes in its facilities, equipment operations or procedures that could affect the operation of this equipment. If this happens, the telephone company will provide advance notice in order for you to make necessary modifications to maintain uninterrupted service. No repairs may be made by the user. If trouble is experienced with Power Pal contact Dataprobe (201.967.9300) for repair or warranty information. If the equipment is causing harm to the telephone network, the telephone company may request that you disconnect the equipment until the problem is resolved.



## FCC Part 15 Class B Registration

This equipment is covered by FCC rules for a Class B computing device.

The following information is provided for the information and guidance of the user. FCC regulations, Part 15 prescribed by the Federal Communications Commission (FCC) specify that we provide the following information:

### WARNING

This equipment generates and uses radio frequency energy and, if not installed and used properly, in strict accordance with the manufacturer's instructions may cause interference to radio and television reception. It has been type tested and found to comply with the limits for a Class B computing device in accordance with the specification in Part 15 of FCC Rules and Regulations, which are designed to provide a reasonable protection against such interference in a residential installation. However, there is no guarantee that interference will not occur in a particular installation.

If this equipment does cause interference to radio or television reception, (which you can determine by turning the equipment OFF and ON), try to correct the interference by one of more of the following measures.

- Reorient the receiving antenna.
- Relocate the computer with respect to the receiver.
- Move the computer away from the receiver.
- Plug the computer into a different outlet so that the computer and receiver are on different branch circuits.

### Notes for Canadian Installations

**Certification Number: 1794 7467 A      Load Number: 6**

The Canadian Department of Communications label identifies certified equipment. This certification means that the equipment meets certain telecommunications network protective, operational and safety requirements. The Department does not guarantee the equipment will operate to the user's satisfaction.

Before installing this equipment, users should ensure that it is permissible to be connected to the facilities of the local telecommunications company. The equipment must also be installed using an acceptable method of connection. The customer should be aware that compliance with the above conditions may not prevent degradation of service in some situations.

"NOTICE: The Load Number (LN) assigned to each terminal device denotes the percentage of the total load to be connected to a telephone loop which is used by the device, to prevent overloading. The terminations on a loop may consist of any combination of devices subject only to the requirement that the sum of the Load Numbers of all devices does not exceed 100". The Power Pal Load Number is 6.

Repairs to certified equipment should be made by an authorized Canadian maintenance facility designated by the supplier. Any repairs or alterations made by the user to this equipment, or equipment malfunctions, may give the telecommunications company cause to request the user to disconnect the equipment.

Users should ensure for their own protection that the electrical ground connections of the power utility, telephone lines and internal metallic water pipe system, if present, are connected together. This precaution may be particularly important in rural areas.

Caution: Users should not attempt to make such connections themselves, but should contact the appropriate electric inspection authority, or electrician, as appropriate. Authorized Canadian service by Signatel, 215 Shields Ct. Markham, Ontario L3R8V2 . Phone: 416-477-9977.

## TECHNICAL SUPPORT, RETURNS AND WARRANTY

Dataprobe Technical Support is available 8:30AM to 5:30PM ET to assist you in the installation and operation of this product. To obtain Technical Support call our Tech Support Hotline at 201-967-8788, or Email us at tech@dataprobe.com. Please have the following information available when you call:

- Model of Product
- Serial Number
- Date of Purchase
- Name of Seller (if other than Dataprobe)

If you purchased this product through an Authorized Dataprobe Reseller, you should contact them first, as they may have information about the application that can more quickly answer your questions.

### WARRANTY

Seller warrants this product, if used in accordance with all applicable instructions, to be free from original defects in material and workmanship for a period of One Year from the date of initial purchase. If the product should prove defective within that period, Seller will repair or replace the product, at its sole discretion.

Service under this Warranty is obtained by shipping the product (with all charges prepaid) to the address below. Seller will pay return shipping charges. Call Dataprobe Technical Service at (201) 967-8788 to receive a Return Materials Authorization (RMA) Number prior to sending any equipment back for repair. Include all cables, power supplies and proof of purchase with shipment.

**THIS WARRANTY DOES NOT APPLY TO NORMAL WEAR OR TO DAMAGE RESULTING FROM ACCIDENT, MISUSE, ABUSE OR NEGLIGENCE. SELLER MAKES NO EXPRESS WARRANTIES OTHER THAN THE WARRANTY EXPRESSLY SET FORTH HEREIN. EXCEPT TO THE EXTENT PROHIBITED BY LAW, ALL IMPLIED WARRANTIES, INCLUDING ALL WARRANTIES OF MERCHANTABILITY OR FITNESS FOR ANY PURPOSE ARE LIMITED TO THE WARRANTY PERIOD SET FORTH ABOVE; AND THIS WARRANTY EXPRESSLY EXCLUDES ALL INCIDENTAL AND CONSEQUENTIAL DAMAGES.**

Some states do not allow limitations on how long an implied warranty lasts, and some states do not allow the exclusion or limitation of incidental or consequential damages, so the above limitations or exclusions may not apply to you. This warranty gives you specific legal rights, and you may have other rights which vary from jurisdictions to jurisdiction.

**WARNING:** The individual user should take care to determine prior to use whether this device is suitable, adequate or safe for the use intended. Since individual applications are subject to great variation, the manufacturer makes no representation or warranty as to the suitability of fitness for any specific application.

**Dataprobe Inc.  
1 Pearl Court  
Allendale, NJ, 07401**