



4 Position Code Activated Switch
Model 4P-CAS
Ver 3.0 and 3.1

INTRODUCTION

The 4 Position Code Activated Switch, **Model 4P-CAS**, allows one RS-232 Master Port to be selectively switched to any of four RS-232 devices. Two modes of operation allow selection of the device to be connected.

In the **Code Control Mode**, the 4P-CAS selects the port to connect to the master based on a three to ten character Switching Code sent to the master port. Each switched port is selected by its own Switching Code.

The 4P-CAS can also be used in a **Code/Lead Control Mode**. In this mode, any of the four ports can access the master port by raising its Request To Send (RTS) or Data Terminal Ready (DTR) control lead. This capability is in addition to the Switching Code selection as described above.

There are four LED's on the front of the 4P-CAS to indicate which port is connected to the master port. A push-button switch on the front panel allows manual port selection. There are four DB25S female connectors on the rear panel for the switched ports, (designated A-D) and a male DB25P connector for the Master Port. Figure 1 illustrates a typical system using the 4P-CAS.

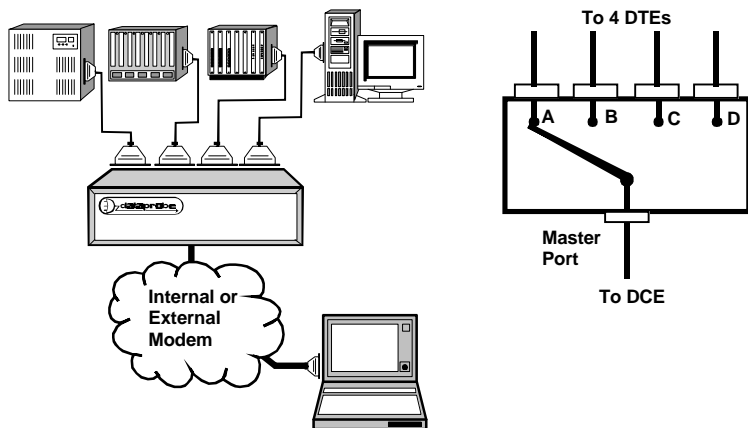

FIGURE 1A and B
4P-CAS Typical Application Used
to access out of band management
ports on four devices

REF: M:\MANUALS\CAS\4P-CAS_V980326R.DOC

Technical Support Hotline: (201) 967-8788



11 Park Place / Paramus, New Jersey 07652
TEL: 201-967-9300 FAX: 201-967-9090
Website: www.dataprobe.com Email: tech@dataprobe.com

PORT SELECTION

Code Control Mode

In the Code Switch Mode, the 4P-CAS constantly monitors the Receive Data (pin 3) on the Master port looking for a preset Switching Code. The Switching Code is a user programmable three to ten character code that selects or de-selects specific ports. The unit is set at the factory as **9600 BPS, 8 Data Bits, 1 Stop Bit, No Parity**. To invoke the auto-rate detector, send the Escape Key one or more times, until the 4P-CAS responds with **4P-CAS READY**. Then the correct syntax for all commands are as follows:

E_{sc}	The Escape Character (Decimal 27 Hex 1B)
< user code >	The Security Code (Default = TEST)
< x >	The Port Letter (A - D)
< EOT >	The End of Text Character (Decimal 04 Hex 04 Ctl+D on the IBM Keyboard)

Select Port	E_{sc} < user code >< x >
Deselect Port	E_{sc} < user code >< EOT >
Query Status	E_{sc} < user code >?
Access Programming Menu	E_{sc} < user code > E_{sc}

Code Control Responses

The 4P-CAS has an option to allow confirmation of switching commands. With this option enabled, the 4P-CAS will report back:

n selected	where 'n' is the current port name (i.e. PORT A)
No ports selected	when all ports are de-selected

Status Query

The user can query the 4P-CAS to determine the current status of the switch. The response will be the same as the Code control response above. The response will be generated even if the command response setting is "N". (See page 5 for command response)

Switch Query Command: *ESC {user code} ?*

Trigger Delay

To prevent the possibility of unwanted switching during binary file transfers, the 4P-CAS will only respond to switching codes if no data has been received by it for 2 seconds prior to the start of the switch code.

Code/Lead Control Mode

This mode allows the RTS or DTR leads of Ports A through D to select the Master Port. This is in addition to the code control functions as described above. Enabling of this function is made using the programming menu. The use of RTS or DTR is selectable on a port by port basis using jumper selections on the printed circuit board. See page 6 for configuration details.

When the selected lead goes high on any of the four ports, it will establish a connection from that port to the master port. This works on a queued basis. (As subsequent ports each raise their lead they will

be serviced in order of appearance). When ports are selected using the Lead Control method, no port status message is generated by the 4P-CAS.

A typical application using CTS for flow control would have RTS and CTS tied together on the master port. When RTS on port A is asserted, CTS on port A also goes high establishing a connection for your hardware. (See Figure 2).

Port Connection

When a port is selected via the Switching Code, the RTS (or DTR) lines will be ignored until the Master Port receives the de-select code. Once the de-select code is received, the 4P-CAS will scan all four ports (from A-D) looking for RTS being asserted. When a RTS is detected, that port is selected and any additional RTS requests are put in the queue, in “first come first serve” order. When the Master Port is selected by an RTS/DTR lead, all Switching Codes and the manual switch will be ignored until all RTS leads go low.

Manual Control

The manual push-button switch on the front panel can be used for local control of the 4P-CAS. Each time the button is depressed, the port will cycle to the next port.

When using the manual push-button in the Code/Lead Control mode, the manual switch will be locked out whenever a port has accessed the Master Port by raising RTS/DTR. In this mode, the push-button can only be used when the 4P-CAS is in the No Port Selected state. To return the 4P-CAS to automatic operation, depress the push-button switch for over two seconds. If no ports are raising RTS/DTR the 4P-CAS will go to the No Ports Selected state (all Port LEDs OFF). If one or more ports are requesting the master, then the port selection will be in “first come first serve” order.

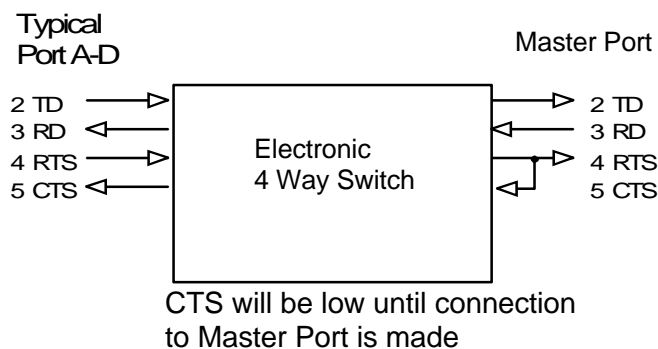

FIGURE 2
Using RTS/CTS in the Code Lead control mode

CONFIGURATION

The 4P-CAS uses a simple programming menu to allow configuration of most operational features. To access this programming menu, connect to the Master Port with a terminal or PC with terminal emulation software and send the Esc character to invoke the auto-rate detector as described on page 2, then after the **4P-CAS READY** message is displayed send:

ESC {user code} ESC The default parameter for the 4P-CAS user code is TEST

If the factory default string TEST has been previously changed, use the new user string instead. This will bring up the programming menu:

PROGRAMMING MENU

```
1) Device labels
2) Password
3) Baud: 9600
4) Parity/Data: N,8
5) Lead: N
6) Resp: N
7) Mode: Modem
8) Time out: 0
X) Exit

Enter >
```

1) Device Labels

This allows changing of the screen labels for the ports.

```
A) PORT A
B) PORT B
C) PORT C
D) PORT D

X) Exit

Enter >
```

Enter the label to be changed. The current label is displayed along with a prompt for the new name. Type in a new label and then confirm the selection. Labels can be up to 24 characters.

```
CURRENT LABEL PORT A PORT A
NEW LABEL PORT A > Your New Name

PORT LABEL CHANGED FROM PORT A
                TO Your New Name
SAVE CHANGES? (Y/N) >
```

2) Password

The password is used for login to the menu system and in every escape sequence. **The factory default is 'TEST'**. The security code may be 1 to 8 characters. These characters can be any ASCII character except NULL (00 hex). To change the password, the current password must be reentered. Then a prompt for a new password, then a confirmation of the new password.

```
LOGIN > TEST
ENTER NEW PASSWORD > TEST
RE-ENTER NEW PASSWORD > TEST
PASSWORD CHANGED
```

3) Baud Rate

The 4P-CAS is capable of operation from 300 BPS to 115200 BPS. Simply enter the desired baud rate followed by the enter key. Valid Selections are:

300 600 1200 2400 4800 9600 19200 38400 57600 and 115200

The baud rate set only effects the code control of the 4P-CAS. Once connection is made to a port, the 4P-CAS is transparent to the speed and character format sent.

4) Parity and Data Bits

The 4P-CAS is capable operating with a 7 or 8 bit data frame, and odd, even or no parity. You need only set the parity, None, Even or Odd. The number of data bits and stop bits is automatically determined.

5) Lead Control

This selection determines whether control leads from the switched ports can be used to access the Master Port. The factory default is lead control disabled. Select Yes or No.

6) Command Response

The 4P-CAS can send a response to escape sequences to let the operator know that the switch has taken place. The factory default is responses disabled. Select Yes or No to change this setting.

7) Modem or Terminal Mode

Sets the 4P-CAS for either Terminal or Modem use. Each time selection 7 is chosen this setting toggles.

Modem Mode

The 4P-CAS monitors the DCD lead from the Master Port. Once the call is established, send the Escape to invoke the auto-rate detector, then send any valid control code. In this mode the Time Out feature, if enabled, will cause the modem to hang up factory default. Use this setting when the 4P-CAS is connected to a dial modem.

Terminal Mode

The 4P-CAS does not monitor the connection status of the Master Port. In this mode the Time Out feature, if enabled, will cause the unit to de-select the port. Use this mode for direct cable connections from a PC or Terminal to the 4P-CAS.

8) Time Out

To prevent one port from dominating access to the Master Port and locking out other selections, a time out feature is incorporated. With the timeout feature enabled, the 4P-CAS monitors the data activity received by the Master Port. When no data is received by the time as set, the currently selected port is de-selected. Set the Time out from 1 to 99 minutes. Setting the Time Out to 0 (default setting) disables the feature and allows unlimited time with no data received. The time out feature affects all selection modes.

X) Exit the Programming Mode

Exit the programming menu and activate all current settings. If the baud rate and/or character format have been changed, Exit will enable those changes.

INSTALLATION

Master and Switched Ports

Connection to the Switched A-D ports is made using 25 pin D Subminiature connectors on the rear of the unit. The following leads are supported for Asynchronous communications:

Pin #	Designation
2	Transmit Data
3	Receive Data
4	Request to Send
5	Clear to Send
6	Data Set Ready
7	Signal Ground
8	Data Carrier Detect
20	Data Terminal Ready

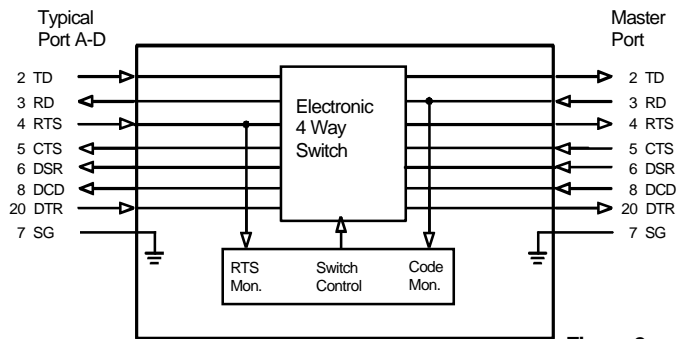

Figure 2 System Diagram

The four switched ports A-D are wired DCE (output data on pin 3,RD). The Master port is wired for as DTE. To directly connect a terminal device to the Master Port, a Null cable is required. Refer to Figure 3.

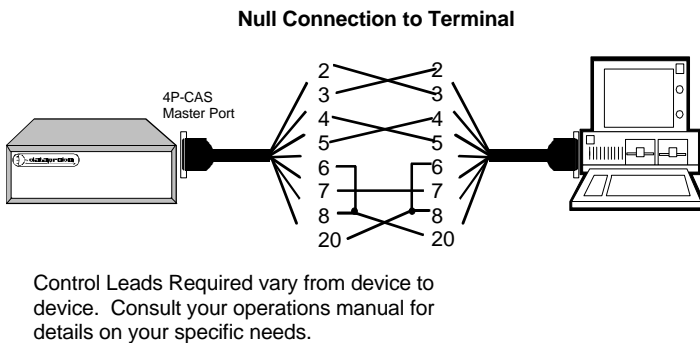

Figure 3 Null Modem Connection

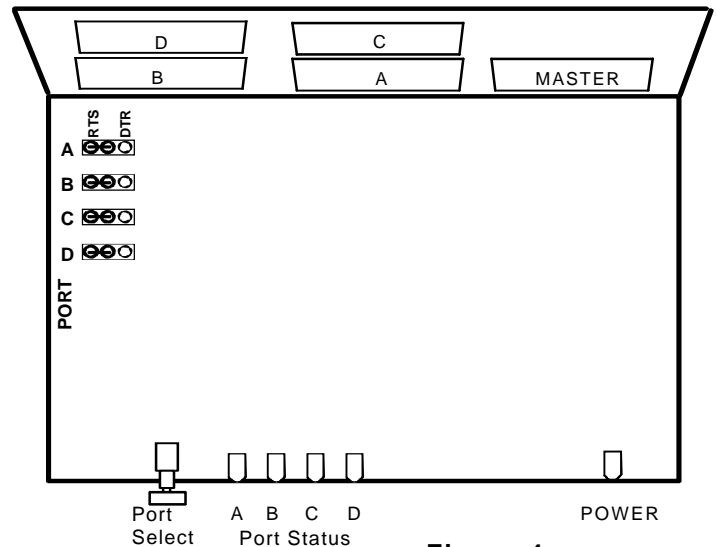

Figure 4 Component Location

RTS / DTR SELECTION

Jumpers JP1 through JP4 allows selection of RTS (default) or DTR as the control lead used for Lead Control. To access these jumpers, disconnect the power source and remove the top cover of the 4P-CAS by loosening the two screws on the underside of the unit. The jumpers are located behind the B and D Port Connectors. See Figure 4.

INTERNAL MODEM OPTION

Dataprobe offers the following internal modem options with the 4P-CAS:

MOD-24 2400bps Modem
MOD-144 14.4 Kbps Modem
MOD-336 33.6 Kbps Modem

These modem options, when ordered with the 4P-CAS are supplied factory installed. They can so be ordered separately for field installation. Information on field installation is supplied with the modem.

Connection to the dial line is made using a RS-232 to Modular Adaptor, **Model MA-CAS**, supplied with the modem. This adaptor connects to the Master Port and to an RJ11 Modular Jack. The modem's FCC registration and AT command set are supplied in a separate document.

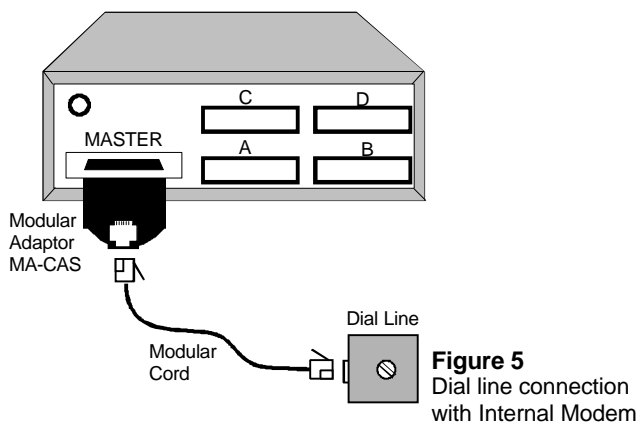

SPECIFICATIONS

Physical

8" Wide x 6.25" Deep x 2.75" High.

Power

Model 4P-CAS 120VAC via Wall Mounted Power Supply, Included. UL/CAS approved.

Model 4P-CAS-12V +12VDC 150 ma required via 3 pin nylon connector, supplied.

Model 4P-CAS-24V +24VDC 100 ma required via 3 pin nylon connector, supplied.

Communications

Speed: 300 to 115,200 bps.

Character Format: 8 data, no parity, 1 stop bit / 7 data even or odd parity, 1 stop bit.

Interface: RS-232 Asynchronous .

Connectors: 25 pin D Subminiature. Master Port is Male, Ports A-D are Female.

Pins Supported: 1-8, 20.

TECHNICAL SUPPORT, RETURNS and WARRANTY

Dataprobe Technical Support is available 8:30AM to 5:30PM ET to assist you in the installation and operation of this product. To obtain Technical Support call our Tech Support Hotline at 201-967-8788, or Email us at tech@dataprobe.com. Please have the following information available when you call:

- Model of Product
- Serial Number
- Data of Purchase
- Name of Seller (if other than Dataprobe)

If you purchased this product through an **Authorized Dataprobe Reseller**, you should contact them first, as they may have information about the application that can more quickly answer your questions.

WARRANTY

Seller warrants this product, if used in accordance with all applicable instructions, to be free from original defects in material and workmanship for a period of One Year from the date of initial purchase. If the product should prove defective within that period, Seller will repair or replace the product, at its sole discretion.

Service under this Warranty is obtained by shipping the product (with all charges prepaid) to the address below. Seller will pay return shipping charges. Call Dataprobe Technical Service at (201) 967-8788 to receive a Return Materials Authorization (RMA) Number prior to sending any equipment back for repair. Include all cables, power supplies and proof of purchase with shipment.

THIS WARRANTY DOES NOT APPLY TO NORMAL WEAR OR TO DAMAGE RESULTING FROM ACCIDENT, MISUSE, ABUSE OR NEGLIGENCE. SELLER MAKES NO EXPRESS WARRANTIES OTHER THAN THE WARRANTY EXPRESSLY SET FORTH HEREIN. EXCEPT TO THE EXTENT PROHIBITED BY LAW, ALL IMPLIED WARRANTIES, INCLUDING ALL WARRANTIES OF MERCHANT ABILITY OR FITNESS FOR ANY PURPOSE ARE LIMITED TO THE WARRANTY PERIOD SET FORTH ABOVE; AND THIS WARRANTY EXPRESSLY EXCLUDES ALL INCIDENTAL AND CONSEQUENTIAL DAMAGES.

Some states do not allow limitations on how long an implied warranty lasts, and some states do not allow the exclusion or limitation of incidental or consequential damages, so the above limitations or exclusions may not apply to you. This warranty gives you specific legal rights, and you may have other rights which vary from jurisdictions to jurisdiction.

WARNING: The individual user should take care to determine prior to use whether this device is suitable, adequate or safe for the use intended. Since individual applications are subject to great variation, the manufacturer makes no representation or warranty as to the suitability of fitness for any specific application.

**Dataprobe Inc.
11 Park Place
Paramus, NJ 07652**